



MODULAR CUBER

PARTS LIST

[HE] [GENERAL(50Hz)(60Hz)][HSP][AUSTRALIA]
[KOREA(60Hz)][CHINA]

E1CK

E1CK-C241,C243,C251,C252,D001

-D002, D003, D004, D005, D007, D008, D009

-D010, D011, D012, D013, D014, D015, D016

-D017, D018, D019, D020, D021, D022, D023

-D024, D025, D026, D027, D028, D029, D030

-D031, D032, D033, D034, D036, D037, D038,

-D039, D040, D041, D042

K-1 JUN. 2010

B-1 APR. 2012

B-2 ----- 2012

B-3 OCT. 2012

C-1 FEB. 2013

G-1 APR. 2017

IM-240DNE

IM-240DNE-C

IM-240DNE-21

IM-240DNE-23

IM-240DNE-32

IM-240XNE

IM-240XNE-21

IM-240XNE-23

IM-240XNE-32

IM-240DSNE

IM-240DSNE-23

IM-240XSNE

IM-240XSNE-23

List of Specifications

IM-240DNE	E1CK	Standard
IM-240DNE	E1CK-C241	For CHINA
IM-240DNE-23	E1CK-C243	For CHINA
IM-240XNE	E1CK-C251	For CHINA
IM-240XNE-23	E1CK-C252	For CHINA
IM-240DNE-C	E1CK-D001	Cylinder ICE of IM-240DNE
IM-240DNE-23	E1CK-D002	23mm ICE of IM-240DNE
IM-240DNE-21	E1CK-D003	21mm ICE of IM-240DNE
IM-240DNE-32	E1CK-D004	32mm ICE of IM-240DNE
IM-240XNE	E1CK-D005	X TYPE
IM-240XNE-23	E1CK-D007	23mm ICE of IM-240XNE
IM-240XNE-21	E1CK-D008	21mm ICE of IM-240XNE
IM-240XNE-32	E1CK-D009	32mm ICE of IM-240XNE
IM-240DNE	E1CK-D010	60Hz of IM-240DNE
IM-240XNE	E1CK-D011	For KOREA 60Hz of IM-240XNE
IM-240DNE-23	E1CK-D012	For KOREA 23mm ICE,60Hz of IM-240DNE
IM-240XNE-23	E1CK-D013	For KOREA 23mm ICE,60Hz of IM-240XNE
IM-240DNE	E1CK-D014	For GENERAL 230V,60Hz of IM-240DNE
IM-240XNE	E1CK-D015	For GENERAL 230V,60Hz of IM-240XNE
IM-240DNE-23	E1CK-D016	For GENERAL 23mm ICE,230V,60Hz of IM-240DNE
IM-240XNE-23	E1CK-D017	For GENERAL 23mm ICE,230V,60Hz of IM-240XNE
IM-240DNE-21	E1CK-D018	For GENERAL 21mm ICE,230V,60Hz of IM-240DNE
IM-240XNE-21	E1CK-D019	For GENERAL 21mm ICE,230V,60Hz of IM-240XNE
IM-240DNE-21	E1CK-D020	For KOREA 21mm ICE,230V,60Hz of IM-240DNE
IM-240XNE-21	E1CK-D021	For KOREA 21mm ICE,230V,60Hz of IM-240XNE
IM-240DNE	E1CK-D022	SUS316 frame of IM-240DNE
IM-240XNE	E1CK-D023	SUS316 frame of IM-240XNE
IM-240DSNE	E1CK-D024	Remote of IM-240DNE
IM-240XSNE	E1CK-D025	Remote of IM-240XNE
IM-240DSNE-23	E1CK-D026	Remote,23mm ICE of IM-240DNE
IM-240XSNE-23	E1CK-D027	Remote,23mm ICE of IM-240XNE
IM-240DNE	E1CK-D028	For GENERAL 230V,60Hz,SUS316 frame of IM-240DNE
IM-240DNE	E1CK-D029	SUS316 frame SUS base of IM-240DNE

List of Specifications

IM-240XNE	E1CK-D030	For GENERAL 230V,60Hz,SUS316 frame of IM-240XNE
IM-240DNE-C	E1CK-D031	SUS316 frame,Cylinder ICE of IM-240DNE
IM-240DNE-23	E1CK-D032	SUS316 frame,23mm ICE of IM-240DNE
IM-240DNE-21	E1CK-D033	SUS316 frame,21mm ICE of IM-240DNE
IM-240DNE-32	E1CK-D034	SUS316 frame,32mm ICE of IM-240DNE
IM-240XNE-23	E1CK-D036	SUS316 frame,23mm ICE of IM-240XNE
IM-240XNE-21	E1CK-D037	SUS316 frame,21mm ICE of IM-240XNE
IM-240XNE-32	E1CK-D038	SUS316 frame,32mm ICE of IM-240XNE
IM-240DNE-23	E1CK-D039	For GENERAL 230V,60Hz,SUS316 frame,23mm ICE of IM-240DNE
IM-240XNE-23	E1CK-D040	For GENERAL 230V,60Hz,SUS316 frame,23mm ICE of IM-240XNE
IM-240DNE-21	E1CK-D041	For GENERAL 230V,60Hz,SUS316 frame,21mm ICE of IM-240DNE
IM-240XNE-21	E1CK-D042	For GENERAL 230V,60Hz,SUS316 frame,21mm ICE of IM-240XNE



PLATON SERVICE
8 (800) 500-3344
www.platonservice.com

AUXILIARY CODE

U - 1

The auxiliary code is the first two characters in the serial number. The first character indicates the production year. Years progress or regress in alphabetical order. The series of letters and skipped letters depend on UL listing, production, and model. See the auxiliary code(s) and corresponding year(s) on the front cover.

The second character indicates significant part changes within the same year. Base is "1" and this number advances for each change. If there is no significant part change at the turn of the year, this number starts from "0."

MARKS LOCATED UNDER THE AUXILIARY CODE

- = Part deleted.
- x = Part deleted and replaced by "o" part.
- o = New part in place of "x" part.

FASTENER PART NUMBER

SCREWS



F S T 0 3 0 6 F 0

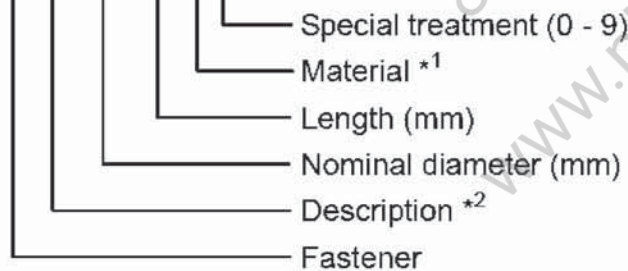

*¹ Material

- F: Steel
- S: Austenitic stainless steel
- M: Martensitic stainless steel
- B: Copper alloy
- P: Polycarbonate
- N: Polyamide
- V: PVC
- A: ABS
- X: Polyacetal
- L: Aluminum

NUTS & WASHERS

F W S P 0 5 S 0

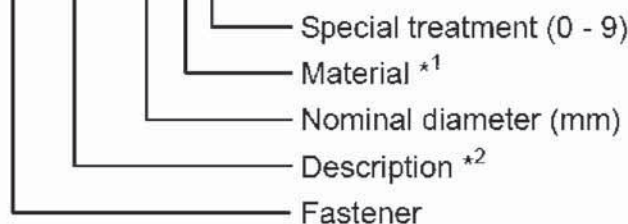

*² Description

- First letter
- S: Machine screw
- T: Tapping screw
- M: Wood screw
- B: Bolt
- W: Washer
- N: Nut

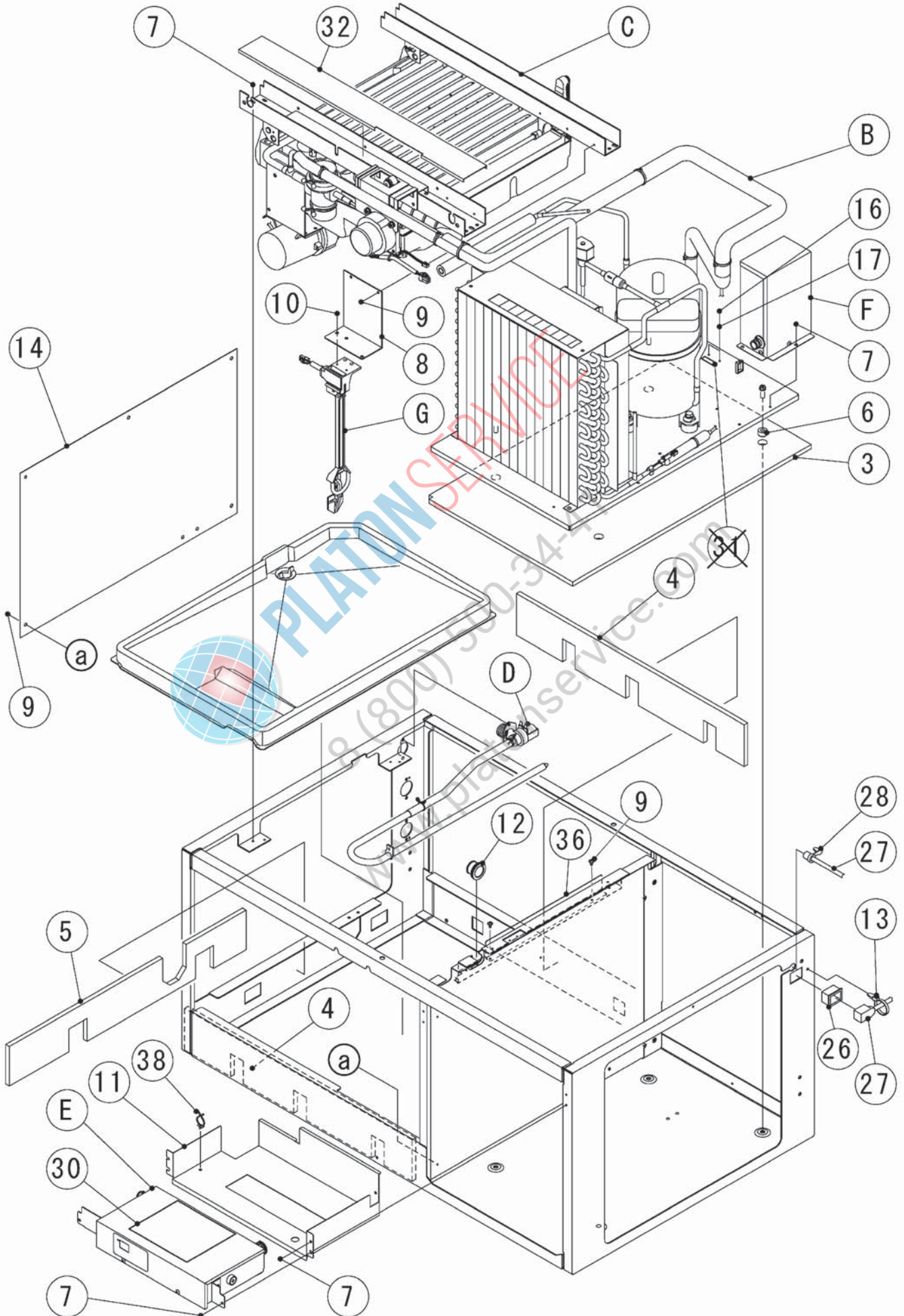

IM-240DNE(-C, -21, -23, -32)
IM-240DSNE(-23)

50Hz (B-1) and later
60Hz (C-1) and later

A. ICE CUBER ASSY (1/2)

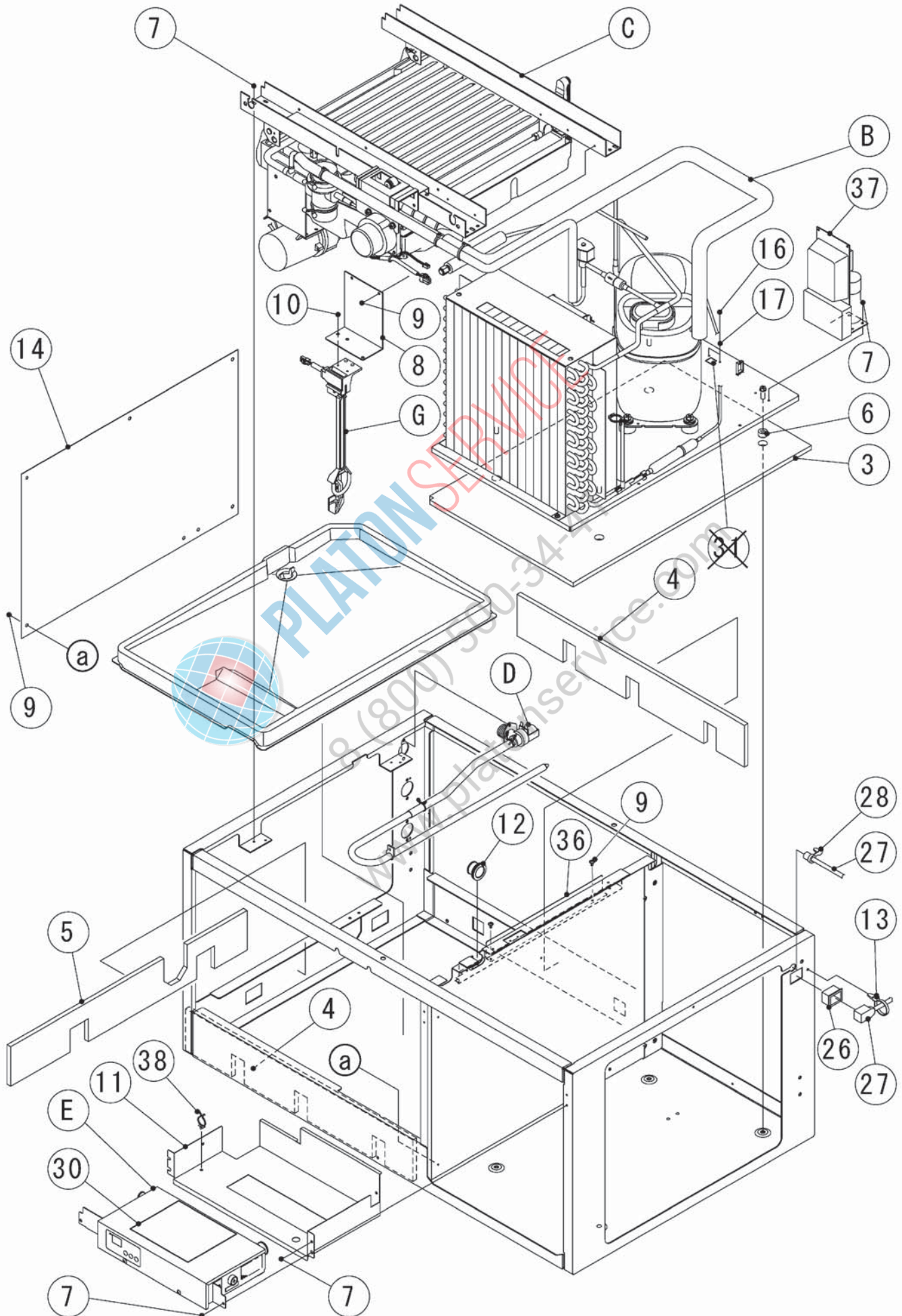

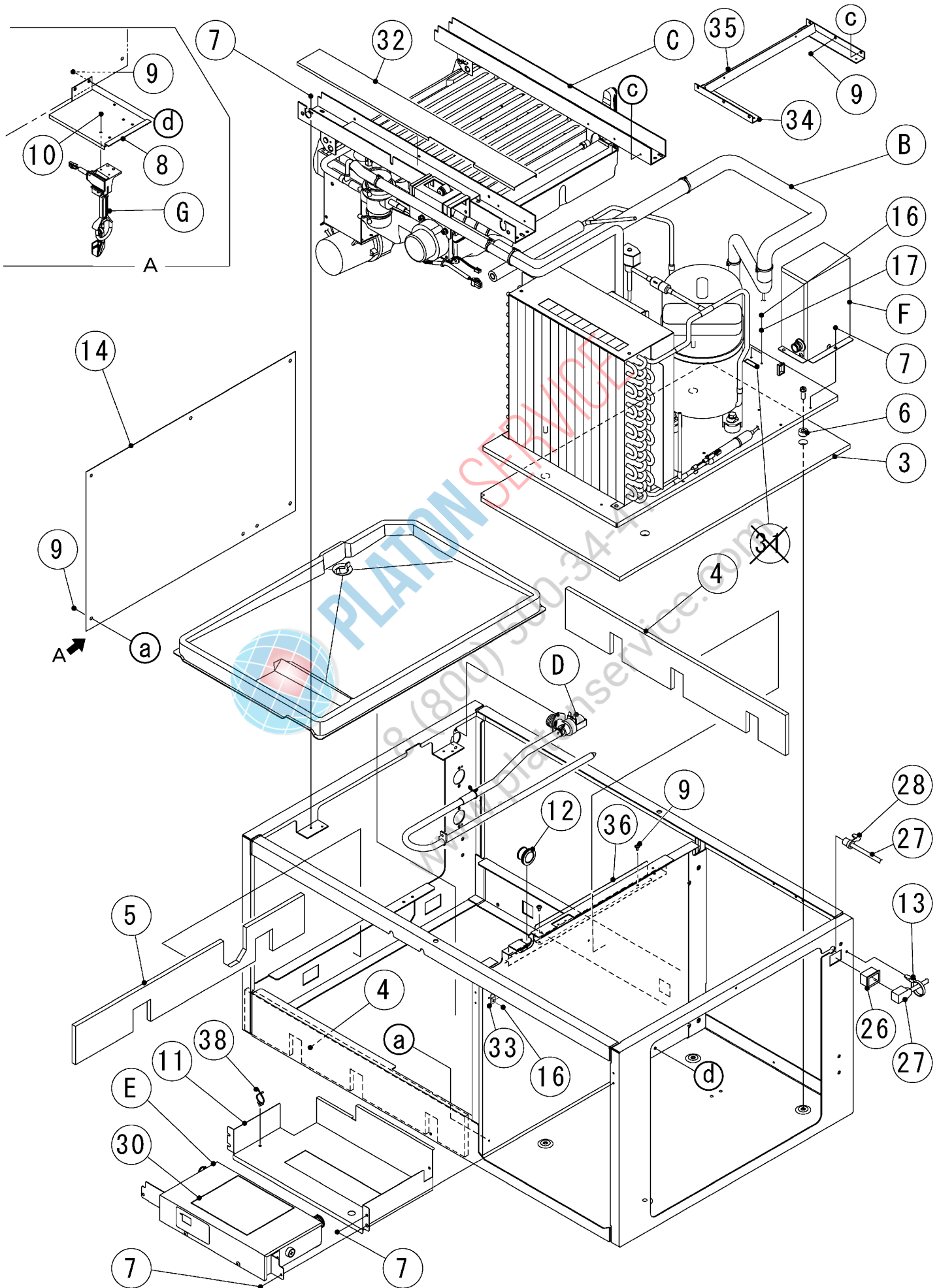

IM-240XNE(-21, -23, -32)
IM-240XSNE(-23)

A. ICE CUBER ASSY (1/2)

50Hz (B-1) and later
60Hz (C-1) and later

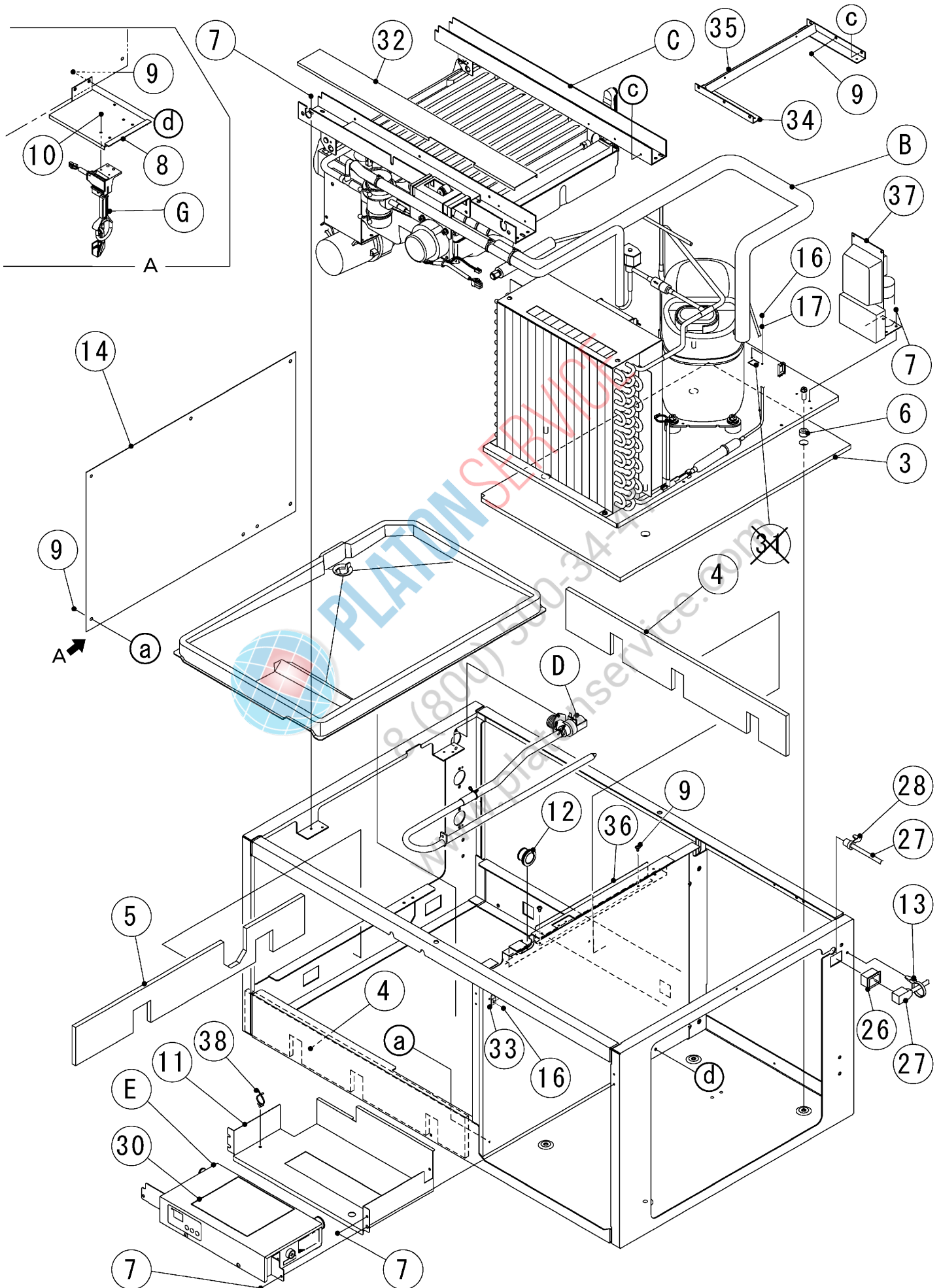

IM-240DNE(-C,-21,-23,-32)

IM-240XNE(-21,-23,-32)

IM-240DSNE(-23)

IM-240XSNE(-23)

A. ICE CUBER ASSY (2/2) (K-1) and later

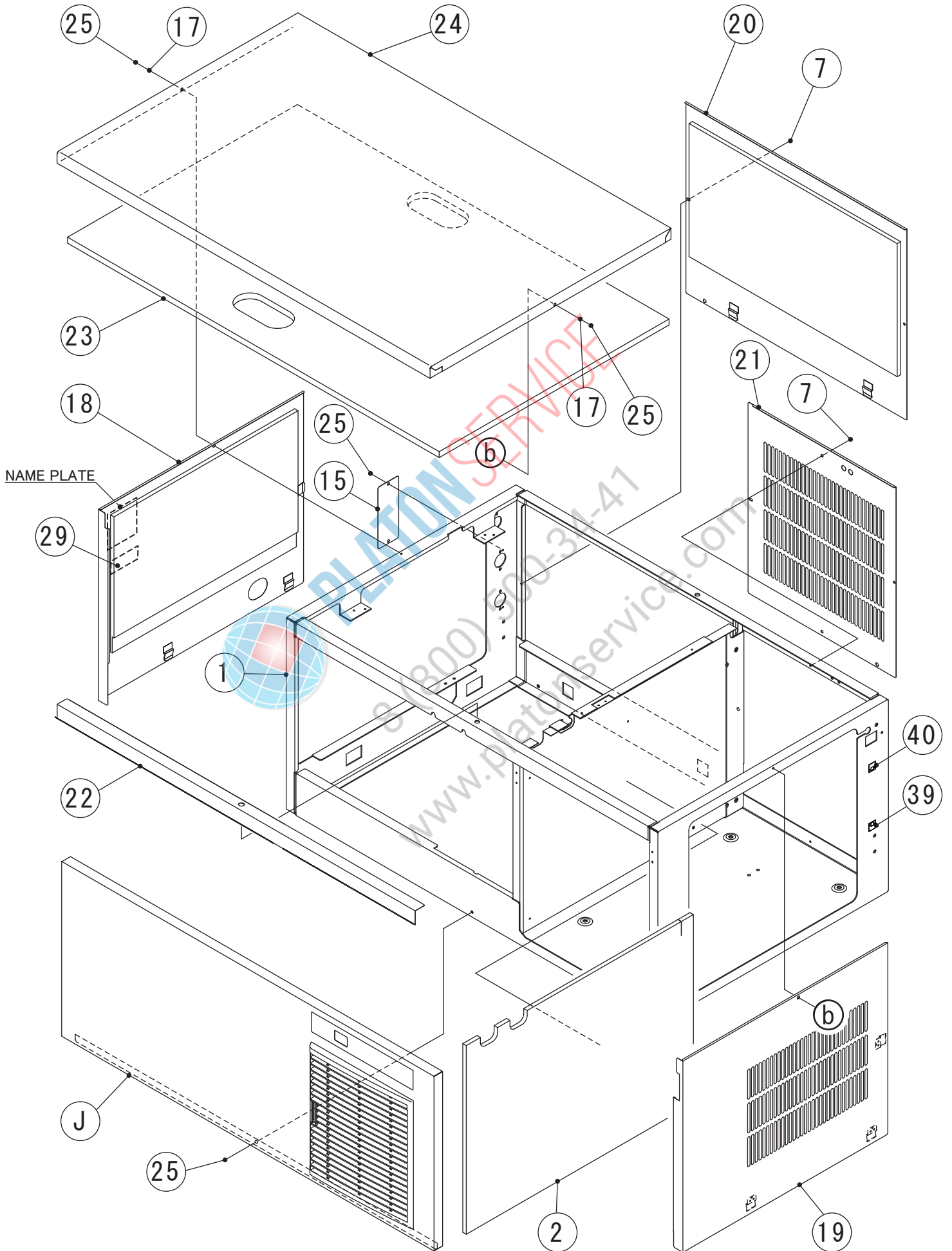

HE,GENERAL(50Hz)(60Hz),HSP,AUSTRALIA,CHINA,KOREA(60Hz)

MODEL : IM-240DNE(-C,-21,-23,-32) IM-240XNE(-21,-23,-32) IM-240DSNE(-23) IM-240XSNE(-23)								
TITLE : A. ICE CUBER ASSY								
INDEX NO.	DESCRIPTION	MATERIAL OR MODEL NUMBER	PART NUMBER	REQ'D NUMBER				
				K-1 B-0	B-1 B-2	B-3 C-0	C-1 G-0	G-1
B	REFRIGERATION ASSY	(50Hz) (EXCEPT 240DNE-C)	1H4668A01	1	-	-	-	-
			1H5184A01	-	1	1	1	1
		(60Hz)	1H4668A01	1	1	1	-	-
			1H5184A01	-	-	-	1	1
		(240DNE-C)	1H4690A01	1	-	-	-	-
			1H5229A01	-	1	1	1	1
(240DSNE,-23) (240XSNE,-23)	1H5295A01				1	1		
C	MECHANISM ASSY	-	1H4669A01	1	1	1	1	1
		(240DNE-C)	1H4679A01	1	1	1	1	1
D	WATER CIRCUIT ASSY	-	2H9942A01	1	1	1	1	1
E	CONTROL BOX ASSY	(50Hz)	2H9968A01	1	-	-	-	-
			2X1162A01	-	1	1	1	1
		(60Hz)	2H9968A01	1	1	1	-	-
			2X1162A01	-	-	-	1	1
		(240DSNE,-23) (240XSNE,-23)	2X1501A01	-	-	-	1	1
F	CONTROL BOX B - ASSY	(50Hz)	3Y5105A01	1	-	-	-	-
		(60Hz)		1	1	1	-	-
G	BIN SWITCH ASSY	(240DNE,-C,-21,-23,-32) (240DSNE,-23)	3Y5222A01	1	1	1	1	1
		(240XNE,-21,-23,-32) (240XSNE,-23)	3Y5244A01	1	1	1	1	1
J	FRONT COVER	(50Hz)	2H9946A01	1	-	-	-	-
			2X1164A01	-	1	1	1	1
		(60Hz)	2H9946A01	1	1	1	-	-
			2X1164A01	-	-	-	1	1
		(240DSNE,-23) (240XSNE,-23)	2X1168A01	-	-	-	1	1
1	UNIT FRAME	-	1H4667G01	1	1	1	1	1
		(240DSNE,-23) (240XSNE,-23)	1H4667G02	-	-	-	1	1
		(SUS316)	1H5205G01	-	1	1	1	1
2	INSULATION - SEPARATOR	-	3Y5008P01	1	1	1	1	1
3	INSULATION - CHASSIS	-	4Y6574P01	1	1	1	1	1
4	INSULATION - FRAME	-	4Y5945P01	2	2	2	2	2
5	INSULATION - SIDEFAME L	-	4Y5944P01	1	1	1	1	1

HE,GENERAL(50Hz)(60Hz),HSP,AUSTRALIA,CHINA,KOREA(60Hz)

MODEL : IM-240DNE(-C,-21,-23,-32) IM-240XNE(-21,-23,-32) IM-240DSNE(-23) IM-240XSNE(-23)								
TITLE : A. ICE CUBER ASSY								
INDEX NO.	DESCRIPTION	MATERIAL OR MODEL NUMBER	PART NUMBER	REQ'D NUMBER				
				K-1 B-0	B-1 B-2	B-3 C-0	C-1 G-0	G-1
6	COLLAR	-	4H8163-01	4	4	4	4	4
7	FLANGE BOLT (S-TITE)	-	FTR0408M0	18	18	18	18	18
8	BRACKET - BIN CONTROL SWITCH	(240DNE,-C,-21,-23,-32) (240DSNE,-23)	4Y7486M01	1	1	1	1	1
		(240XNE,-21,-23,-32) (240XSNE,-23)	4Y5943M01	1	1	1	1	1
9	TRUSS HEAD TAPPING SCREW T2	(240DNE,-C,-21,-23,-32) (240DSNE,-23)	FT20408S0	9	9	9	9	9
		(240XNE,-21,-23,-32) (240XSNE,-23)		15	15	15	15	15
10	TRUSS HEAD TAPPING SCREW T2	-	FT20412S0	2	2	2	2	2
11	UNIT BOX	-	2H9970M01	1	1	1	1	1
12	GROMMET	-	4H2568-01	1	1	1	1	1
13	PUSH MOUNT TIE	T30RSF	436156-01	1	1	1	1	1
14	PROTECTOR - SEPARATOR	(50Hz)	3Y4267P01	1	-	-	-	-
		(60Hz)		1	1	1	-	-
		(240DSNE,-23) (240XSNE,-23)		-	-	-	1	1
15	PLATE	-	4Y2479-01	1	1	1	1	1
16	TRUSS HEAD MACHINE SCREW	(240DNE,-C,-21,-23,-32) (240DSNE,-23)	FST0408S0	2	2	2	2	2
		(240XNE,-21,-23,-32) (240XSNE,-23)		3	3	3	3	3
17	SPRING WASHER	-	FWSP04S0	4	4	4	4	4
18	SIDE PANEL - L	-	3Y5012G01	1	1	1	1	1
19	SIDE PANEL - R	-	3Y5013G01	1	1	1	1	1
20	REAR PANEL	-	3Y5016G01	1	1	1	1	1
21	REAR PANEL R	-	3Y5018M01	1	1	1	1	1
22	HOOK - TOP PANEL	-	3Y5019M01	1	1	1	1	1
23	INSULATION - TOP PANEL	(240DNE,-C,-21,-23,-32) (240DSNE,-23)	3H9603-01	1	1	1	1	1
24	TOPPANEL	(240DNE,-C,-21,-23,-32) (240DSNE,-23)	1H4725M01	1	1	1	1	1
25	TRUSS HEAD TAPPING SCREW (S-TITE)	-	FTS0408M0	5	5	5	5	5
26	CONNECTOR	-	P00246-01	1	1	1	1	1

HE, GENERAL, HSP, AUSTRALIA, CHINA

IM-240DNE (-21, -23, -32)

IM-240XNE (-21, -23, -32)

B. REFRIGERATION ASSY

50Hz (K-1) to (B-0)

60Hz (K-1) to (C-0)

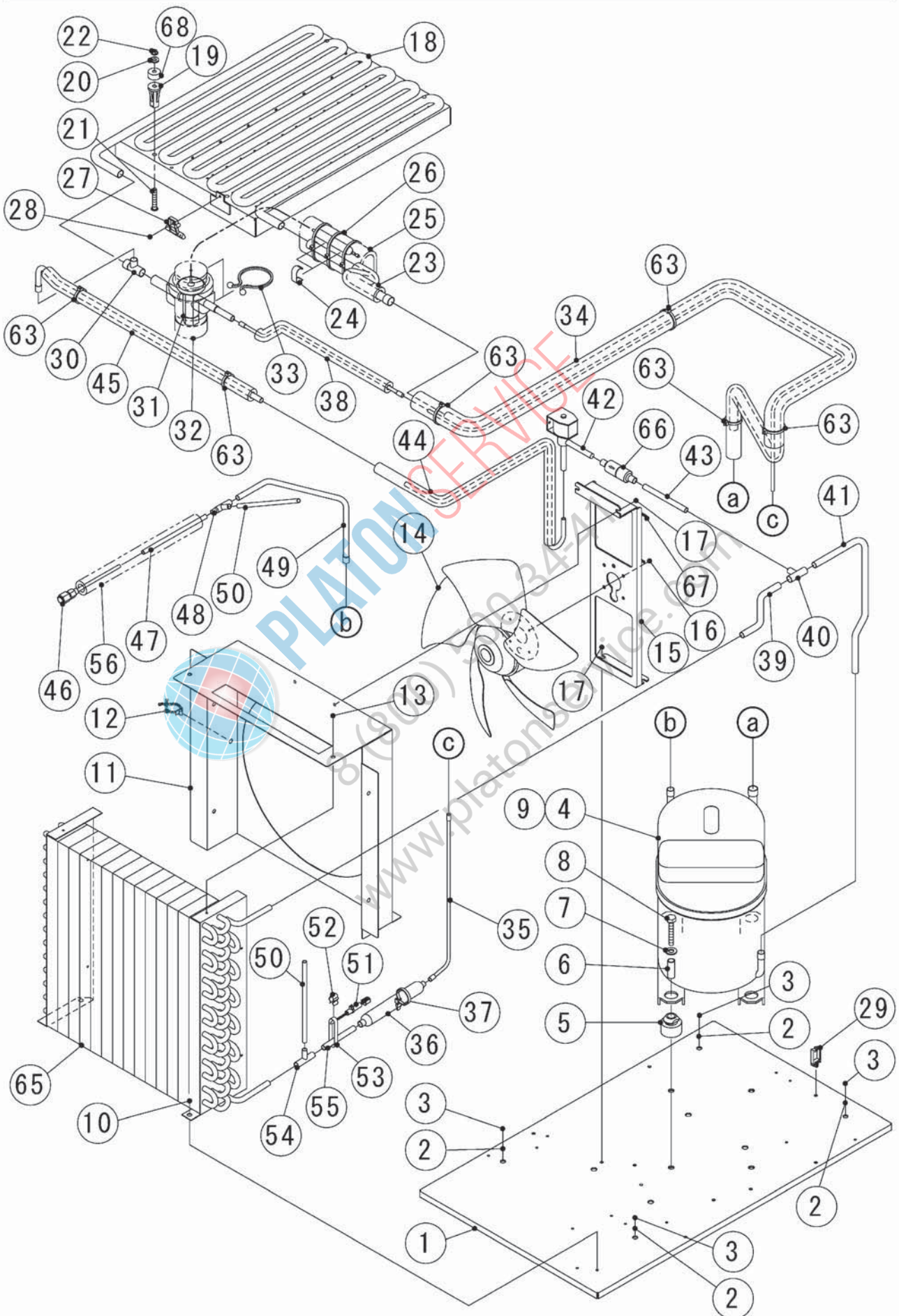

HE, GENERAL (50Hz), HSP, AUSTRALIA, CHINA
IM-240DNE (-21, -23, -32)
IM-240XNE (-21, -23, -32)

(50Hz)

B. REFRIGERATION ASSY

(B-1) and later

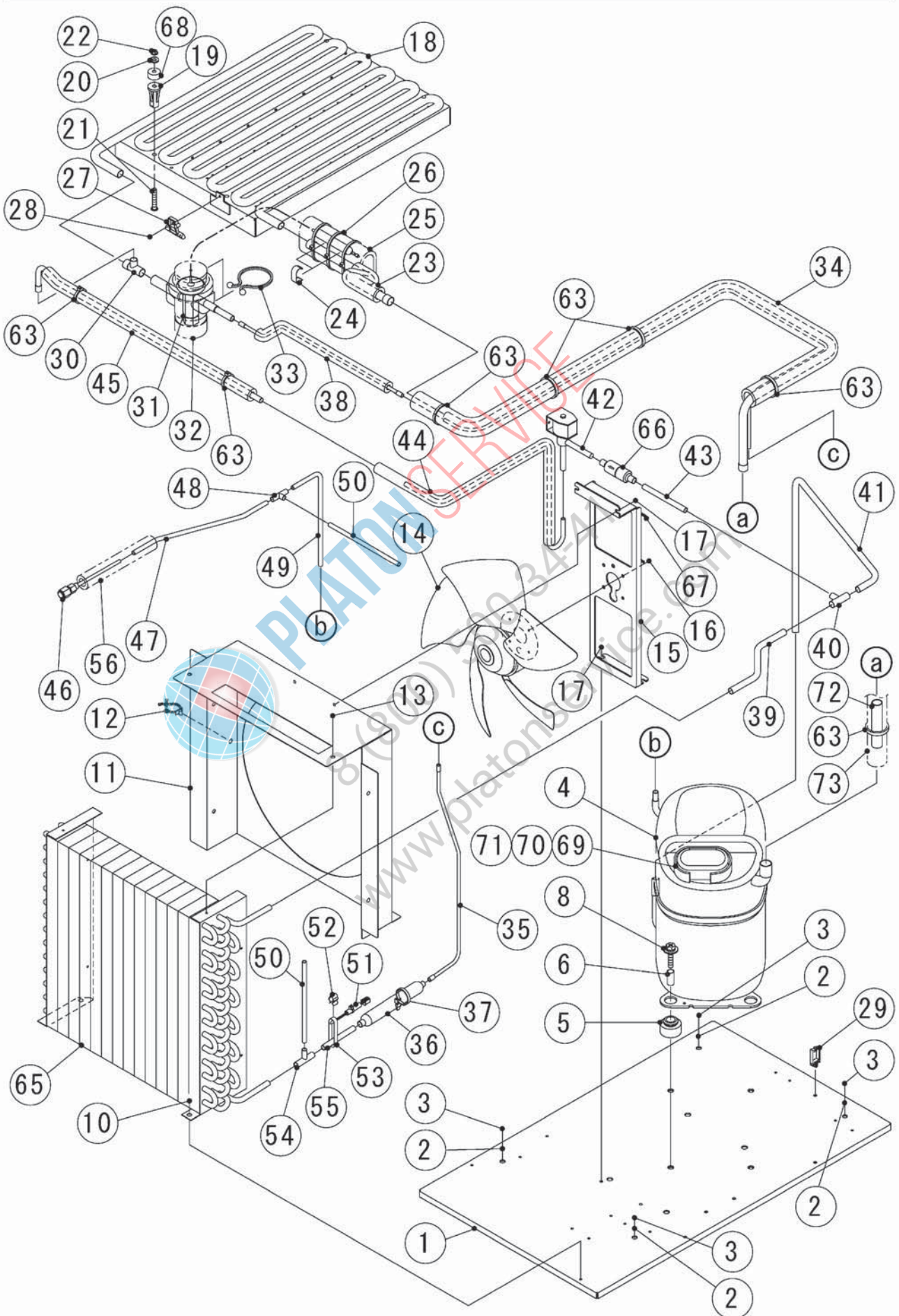

HE, GENERAL (60Hz), HSP, AUSTRALIA, CHINA

IM-240DNE (-21, -23, -32)

IM-240XNE (-21, -23, -32)

(60Hz)

B. REFRIGERATION ASSY

(C-1) and later

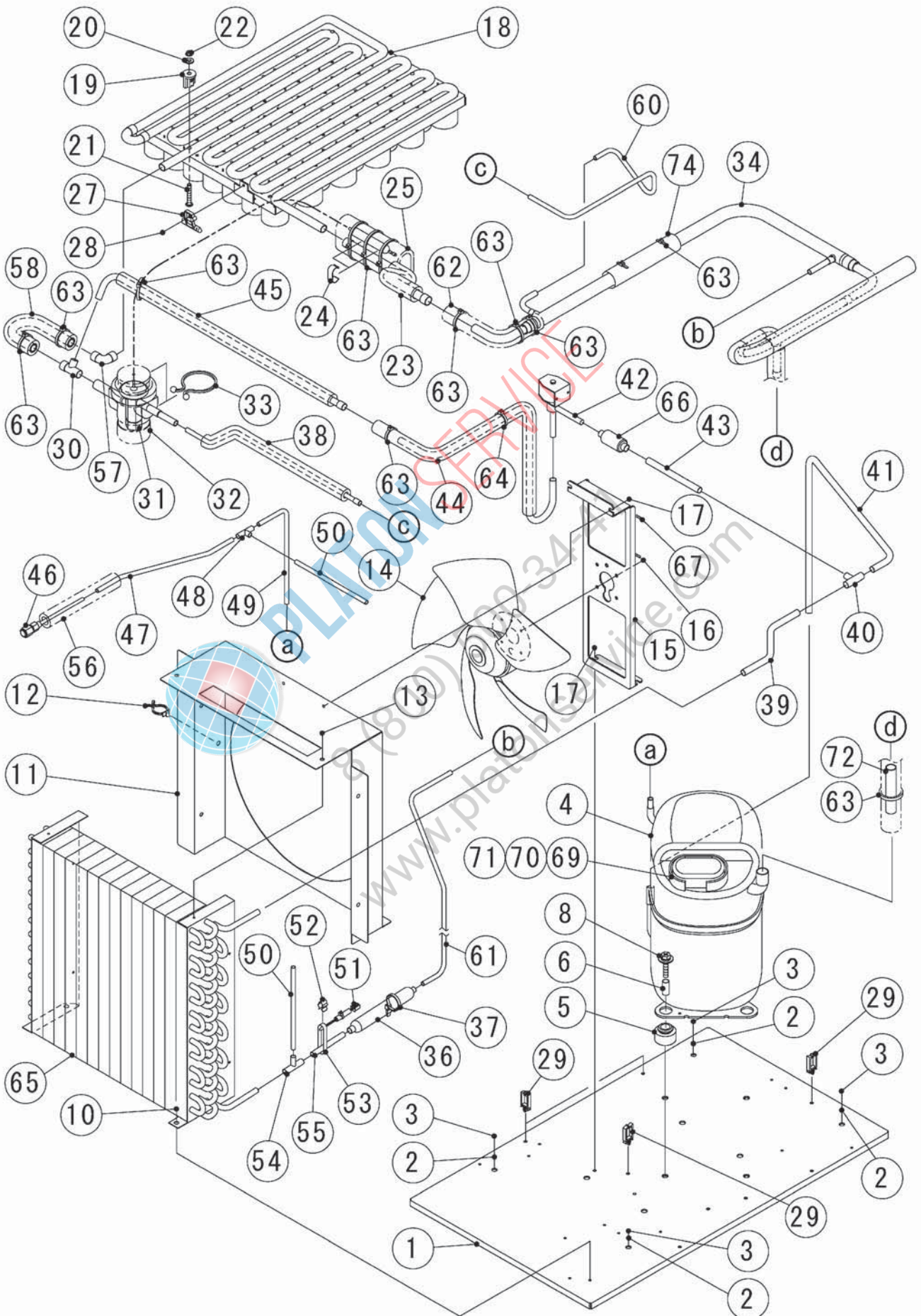

IM-240DNE-C B. REFRIGERATION ASSY

(K-1) to (B-0)

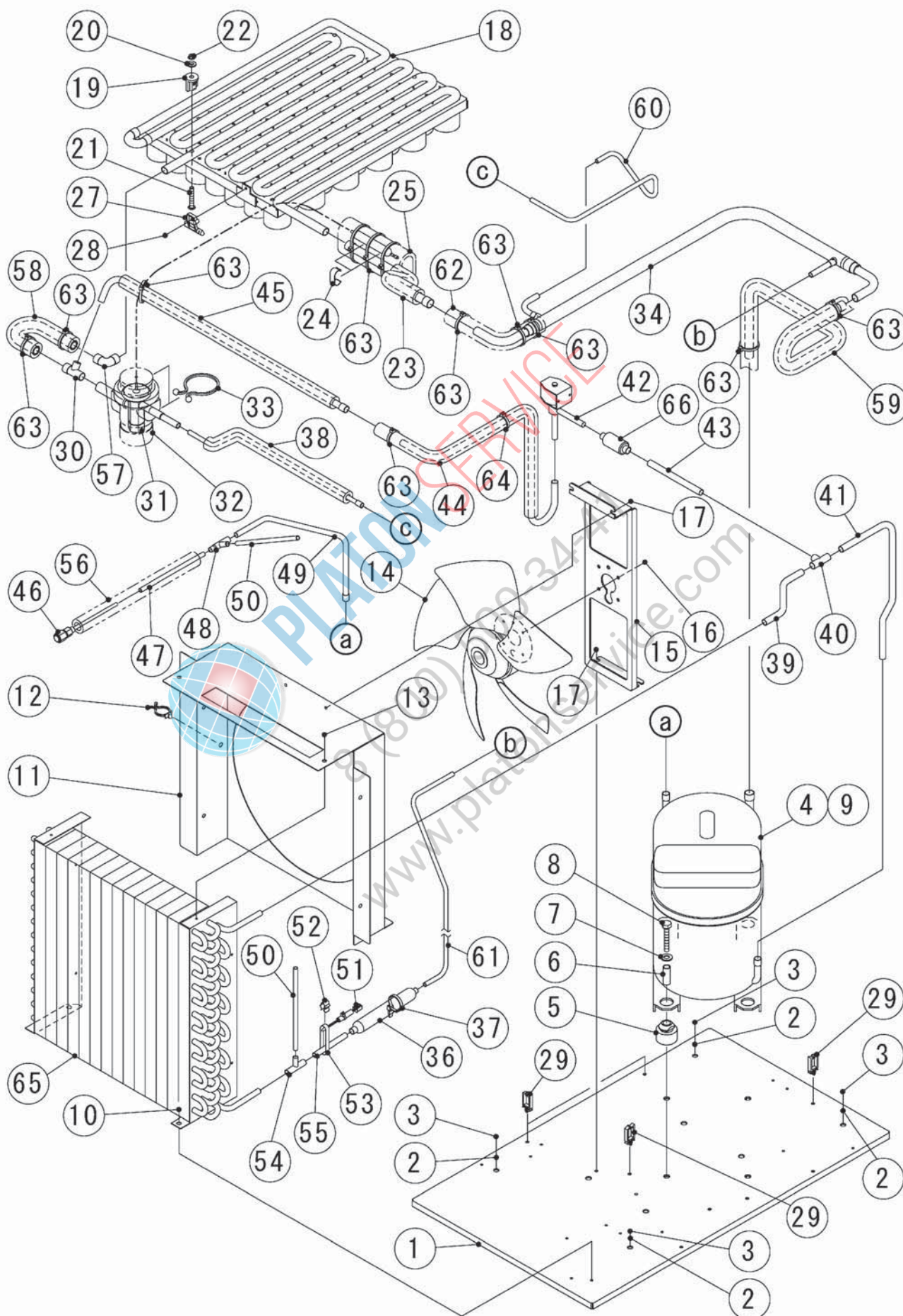

MODEL : **IM-240DNE(-C,-21,-23,-32)**
IM-240XNE(-21,-23,-32)

TITLE : **B. REFRIGERATION ASSY**

INDEX NO.	DESCRIPTION	MATERIAL OR MODEL NUMBER	PART NUMBER	REQ'D NUMBER				
				K-1 B-0	B-1 B-2	B-3 C-0	C-1 G-0	G-1
1	BASE	(50Hz)	3Y5023G01	1	-	-	-	-
			3Y6693G01	-	1	1	1	1
2	FLAT WASHER	-	FWPL06N0	4	4	4	4	4
3	HEX HEAD BOLT	-	FBH0620S0	4	4	4	4	4
4	COMPRESSOR	(50Hz)	4A1581-01	1	-	-	-	-
			P01855-01	-	1	1	1	1
5	GROMMET	(50Hz)	434922-02	4	-	-	-	-
	RUBBER GROMMET		P01858-01	-	4	4	4	4
6	SPACER	(50Hz)	434921-01	4	-	-	-	-
	SLEEVE		P01859-01	-	4	4	4	4
7	FLAT WASHER	-	FWPL08F0	-	-	-	-	-
8	BOLT	(50Hz)	436206-04	4	-	-	-	-
			436206-03	-	4	4	4	4
9	MOTOR PROTECTOR	(50Hz)	4A1581F01	1	-	-	-	-
10	FLANGE BOLT (S-TITE)	-	FTR0408M0	2	2	2	2	2
11	SHROUD	-	2H9947M01	1	1	1	1	1
12	CLAMP	No.2674	427902-02	1	1	1	1	1
13	TRUSS HEAD TAPPING SCREW T2	-	FT20408F0	6	6	6	6	6
14	FAN MOTOR	A4E300-AS72-01	P02545-01	1	1	1	1	1
15	BRACKET - FM	-	3Y5075M01	1	1	1	1	1
16	HEX HEAD BOLT (SPRING WASHER AND FLAT WASHER)	-	FBK0408F0	5	5	5	5	5
17	HEX HEAD BOLT (SPRING WASHER AND FLAT WASHER)	-	FBK0508F0	4	4	4	4	4
18	EVAPORATOR	(240DNE,XNE)	2H7526G02	1	1	1	1	1
		(240DNE-C)	2H9949G01	1	1	1	1	1
		(240DNE-21,XNE-21)	208205G04	1	1	1	1	1
		(240DNE-23,XNE-23)	2H1833G03	1	1	1	1	1
		(240DNE-32,XNE-32)	2H3631G02	1	1	1	1	1
19	COLLAR	-	3H3879-01	4	4	4	4	4
	SPACER	(240DNE-C)	4H0471-01	4	4	4	4	4
20	WASHER	-	4H0777-01	4	4	4	4	4
21	SCREW EVAPORATOR	(240DNE,DNE-32, 240XNE,XNE-32)	4Y4922M02	4	4	4	4	4
		(240DNE-C)	4Y4922M01	4	4	4	4	4
		240DNE-21,-23, 240XNE-21,-23	4Y4922M03	4	4	4	4	4
22	FLANGE NUT	-	FNHF06S0	4	4	4	4	4

MODEL : **IM-240DNE(-C,-21,-23,-32)**
IM-240XNE(-21,-23,-32)

TITLE : **B. REFRIGERATION ASSY**

INDEX NO.	DESCRIPTION	MATERIAL OR MODEL NUMBER	PART NUMBER	REQ'D NUMBER				
				K-1 B-0	B-1 B-2	B-3 C-0	C-1 G-0	G-1
23	PIPE(B) - LOW SIDE	-	4Y6625G01	1	1	1	1	1
24	CLIP	-	452254-02	2	2	2	2	2
25	INSULATION	-	4X8643-01	1	1	1	1	1
26	NYLON TIE	(240DNE)	7920-0002	3	3	3	3	3
27	HOLDER - THERMISTOR	-	3H9642-01	1	1	1	1	1
28	TRUSS HEAD TAPPING SCREW (S-TITE)	-	FTS0408M0	1	1	1	1	1
29	WIRE SADDLE	-	428060-02	1	1	1	1	1
30	TEE	-	430608-01	1	1	1	1	1
31	EXPANSION VALVE	FRE-10NHD-3	P01874-01	1	1	1	1	1
32	VALVE COVER	-	3Y3051P01	1	1	1	1	1
33	CLAMP	18T6	P00752-01	2	2	2	2	2
34	HEAT EXCHANGER	(50Hz)	2X0035G01	1	-	-	-	-
			2X1147G01	-	1	1	1	1
		(240DNE-C)	3Y3207G01	1	1	1	1	1
35	PIPE(C-2) - HIGH SIDE	(50Hz)	4Y6694M01	1	-	-	-	-
	PIPE(B)-HIGH SIDE	(EXCEPT 240DNE-C)	4Y7777M01	-	1	1	1	1
36	DRIER		458776-01	1	1	1	1	1
		(240DNE-C)	P00026-01	1	1	1	1	1
37	TIE		457167-01	1	1	1	1	1
38	PIPE(C) - HIGH SIDE		3Y5067G01	1	1	1	1	1
		(240DNE-C)	3Y5074G01	1	1	1	1	1
39	PIPE(B) - HIGH SIDE	(50Hz)	4Y6691M01	1	-	-	-	-
			4Y7778M01	-	1	1	1	1
40	TEE	-	420041-09	1	1	1	1	1
		(240DNE-C)	417394-02	1	1	1	1	1
41	PIPE(A) - HIGH SIDE	(50Hz)	4Y6693M01	1	-	-	-	-
			3Y6687M01	-	1	1	1	1
42	HOT GAS VALVE		P04242-01	1	1	1	1	1
43	PIPE(A) - HOT GAS	-	4Y6692M01	1	1	1	1	1
		(240DNE-C)	4Y6626M02	1	1	1	1	1
44	PIPE(B) - HOT GAS	-	3Y5135G01	1	1	1	1	1
		(240DNE-C)	3Y5150G01	1	1	1	1	1
45	PIPE(C) - HOT GAS	-	3Y5069G01	1	1	1	1	1
		(240DNE-C)	3Y5073G01	1	1	1	1	1
46	ACCESS VALVE	-	455119-01	1	1	1	1	1

MODEL : **IM-240DNE(-C,-21,-23,-32)**
IM-240XNE(-21,-23,-32)

TITLE : **B. REFRIGERATION ASSY**

INDEX NO.	DESCRIPTION	MATERIAL OR MODEL NUMBER	PART NUMBER	REQ'D NUMBER				
				K-1 B-0	B-1 B-2	B-3 C-0	C-1 G-0	G-1
47	PIPE(B) - PROCESS	(50Hz)	4Y6621M01	1	-	-	-	-
			4Y7779M01	-	1	1	1	1
48	TEE	(50Hz)	420041-03	1	-	-	-	-
			417394-01	-	1	1	1	1
49	PIPE(A) - PROCESS	(50Hz)	4Y6651M01	1	-	-	-	-
			4Y7780M01	-	1	1	1	1
50	PROCESS TUBE	-	4Y0273-01	2	2	2	2	2
51	THERMISTOR(G) - FILTER	-	4Y4859G01	1	1	1	1	1
52	CLIP - THERMISTOR	-	4R2938-01	1	1	1	1	1
53	ALUMINUM TAPE	(50Hz)	1H4668-01	1	-	-	-	-
			1H5184Z01	-	1	1	1	1
		(240DNE-C)	1H5229-01	-	1	1	1	1
54	TEE	-	420041-02	1	1	1	1	1
55	PIPE(F) - HIGH SIDE	-	4Y6750M01	1	1	1	1	1
56	INSULATION TUBE	(50Hz)	H71323250	1	-	-	-	-
			H71323150	-	1	1	1	1
57	ELBOW	(240DNE-C)	417395-03	1	1	1	1	1
58	CONNECT PIPE	(240DNE-C)	4Y6781G01	1	1	1	1	1
59	PIPE(A)-LOW SIDE	(240DNE-C)	3Y5099G01	1	-	-	-	-
			3Y6825G01	-	1	1	1	1
60	PIPE(E) - HIGH SIDE	(240DNE-C)	4Y6627M01	1	1	1	1	1
61	PIPE(D) - HIGH SIDE	(240DNE-C)	3Y5072M01	1	-	-	-	-
			3Y5072M02	-	1	1	1	1
62	INSULATION TUBE	(240DNE-C)	H72030B20	1	1	1	1	1
63	TIE	-	7920-0003	6	6	6	6	6
		(240DNE-C)	7920-0003	12	13	13	13	13
64	NYLON TIE	(240DNE-C)	7920-0010	1	1	1	1	1
65	CONDENSER	-	P03307-01	1	1	1	1	1
		(CHINA)	P01875-01	1	1	1	1	1
66	STRAINER	-	P00812-01	1	1	1	1	1
		(240DNE-C)	430365-05	1	1	1	1	1
67	TIE	-	7920-0002	2	2	2	2	2
68	WASHER	(240DNE-21,XNE-21)	4H1365-06	4	4	4	4	4
	WASHER	(240DNE-23,XNE-23)	4H1365-05	4	4	4	4	4
69	COVER	(50Hz)	P01857-01	-	1	1	1	1

MODEL : **IM-240DNE(-C,-21,-23,-32)**
IM-240XNE(-21,-23,-32)

TITLE : **B. REFRIGERATION ASSY**

INDEX NO.	DESCRIPTION	MATERIAL OR MODEL NUMBER	PART NUMBER	REQ'D NUMBER				
				K-1 B-0	B-1 B-2	B-3 C-0	C-1 G-0	G-1
70	CLAMP	(50Hz)	P01862-01	-	1	1	1	1
71	GASKET	(50Hz)	P01863-01	-	1	1	1	1
72	PIPE(A-2)-LOW SIDE	(50Hz)	4Y6612M01	-	1	1	1	1
73	INSULATION TUBE	(50Hz)	H72030300	-	1	1	1	1
74	INSULATION TUBE	(240DNE-C)	H72030B15	-	1	1	1	1



PLATON SERVICE

8 (800) 500-34-41

www.platonservice.com

MODEL : **IM-240DNE(-C,-21,-23,-32)**
IM-240XNE(-21,-23,-32)

TITLE : **B. REFRIGERATION ASSY**

INDEX NO.	DESCRIPTION	MATERIAL OR MODEL NUMBER	PART NUMBER	REQ'D NUMBER				
				K-1 B-0	B-1 B-2	B-3 C-0	C-1 G-0	G-1
1	BASE	(60Hz)	3Y5023G01	1	1	1	-	-
			3Y6693G01	-	-	-	1	1
2	FLAT WASHER	-	FWPL06N0	4	4	4	4	4
3	HEX HEAD BOLT	-	FBH0620S0	4	4	4	4	4
4	COMPRESSOR	(60Hz)	4A1322-01	1	1	1	-	-
			P02886-01	-	-	-	1	1
5	GROMMET	(60Hz)	434922-02	4	4	4	-	-
	RUBBER GROMMET		P01858-01	-	-	-	4	4
6	SPACER	(60Hz)	434921-01	4	4	4	-	-
	SLEEVE		P01859-01	-	-	-	4	4
7	FLAT WASHER	-	FWPL08F0	-	-	-	-	-
8	BOLT	(60Hz)	436206-04	4	4	4	-	-
			436206-03	-	-	-	4	4
9	MOTOR PROTECTOR	(60Hz)	4A1581F01	1	1	1	-	-
10	FLANGE BOLT (S-TITE)	-	FTR0408M0	2	2	2	2	2
11	SHROUD	-	2H9947M01	1	1	1	1	1
12	CLAMP	No.2674	427902-02	1	1	1	1	1
13	TRUSS HEAD TAPPING SCREW T2	-	FT20408F0	6	6	6	6	6
14	FAN MOTOR	A4E300-AS72-01	P02545-01	1	1	1	1	1
15	BRACKET - FM	-	3Y5075M01	1	1	1	1	1
16	HEX HEAD BOLT (SPRING WASHER AND FLAT WASHER)	-	FBK0408F0	5	5	5	5	5
17	HEX HEAD BOLT (SPRING WASHER AND FLAT WASHER)	-	FBK0508F0	4	4	4	4	4
18	EVAPORATOR	(240DNE,XNE)	2H7526G02	1	1	1	1	1
		(240DNE-21,XNE-21)	208205G04	1	1	1	1	1
		(240DNE-23,XNE-23)	2H1833G03	1	1	1	1	1
		(240DNE-32,XNE-32)	2H3631G02	1	1	1	1	1
19	COLLAR	-	3H3879-01	4	4	4	4	4
20	WASHER	-	4H0777-01	4	4	4	4	4
21	SCREW EVAPORATOR	(240DNE,DNE-32, 240XNE,XNE-32)	4Y4922M02	4	4	4	4	4
		240DNE-21,-23, 240XNE-21,-23	4Y4922M03	4	4	4	4	4
22	FLANGE NUT	-	FNHF06S0	4	4	4	4	4
23	PIPE(B) - LOW SIDE	-	4Y6625G01	1	1	1	1	1

HE,GENERAL(60Hz),HSP,AUSTRALIA,CHINA,KOREA(60Hz)

[60Hz]

MODEL : IM-240DNE(-C,-21,-23,-32)
IM-240XNE(-21,-23,-32)

TITLE : B. REFRIGERATION ASSY

INDEX NO.	DESCRIPTION	MATERIAL OR MODEL NUMBER	PART NUMBER	REQ'D NUMBER				
				K-1 B-0	B-1 B-2	B-3 C-0	C-1 G-0	G-1
24	CLIP	-	452254-02	2	2	2	2	2
25	INSULATION	-	4X8643-01	1	1	1	1	1
26	NYLON TIE	(240DNE)	7920-0002	3	3	3	3	3
27	HOLDER - THERMISTOR	-	3H9642-01	1	1	1	1	1
28	TRUSS HEAD TAPPING SCREW (S-TITE)	-	FTS0408M0	1	1	1	1	1
29	WIRE SADDLE	-	428060-02	1	1	1	1	1
30	TEE	-	430608-01	1	1	1	1	1
31	EXPANSION VALVE	FRE-10NHD-3	P01874-01	1	1	1	1	1
32	VALVE COVER	-	3Y3051P01	1	1	1	1	1
33	CLAMP	18T6	P00752-01	2	2	2	2	2
34	HEAT EXCHANGER	(KOREA 60Hz GENERAL 60Hz)	3Y3207G01	1	1	1	1	1
36	DRIER	-	458776-01	1	1	1	1	1
37	TIE	-	457167-01	1	1	1	1	1
38	PIPE(C) - HIGH SIDE	-	3Y5067G01	1	1	1	1	1
39	PIPE(B) - HIGH SIDE	(60Hz)	4Y6691M01	1	1	1	-	-
			4Y7778M01	-	-	-	1	1
40	TEE	-	420041-09	1	1	1	1	1
41	PIPE(A) - HIGH SIDE	(60Hz)	4Y6693M01	1	1	1	-	-
			3Y6687M01	-	-	-	1	1
42	HOT GAS VALVE	ATS-7S23HD-1	P01871-01	1	1	1	1	1
43	PIPE(A) - HOT GAS	-	4Y6692M01	1	1	1	1	1
44	PIPE(B) - HOT GAS	-	3Y5135G01	1	1	1	1	1
45	PIPE(C) - HOT GAS	-	3Y5069G01	1	1	1	1	1
46	ACCESS VALVE	-	455119-01	1	1	1	1	1
47	PIPE(B) - PROCESS	(60Hz)	4Y6621M01	1	1	1	-	-
			4Y7779M01	-	-	-	1	1
48	TEE	(60Hz)	420041-03	1	1	1	-	-
			417394-01	-	-	-	1	1
49	PIPE(A) - PROCESS	(60Hz)	4Y6651M01	1	1	1	-	-
			4Y7780M01	-	-	-	1	1
50	PROCESS TUBE	-	4Y0273-01	2	2	2	2	2
51	THERMISTOR(G) - FILTER	-	4Y4859G01	1	1	1	1	1
52	CLIP - THERMISTOR	-	4R2938-01	1	1	1	1	1
53	ALUMINUM TAPE	(60Hz)	1H4668-01	1	1	1	-	-
			1H5184Z01	-	-	-	1	1

IM-240DSNE (-23)
IM-240XSNE (-23)

B. REFRIGERATION ASSY (C-1) and later

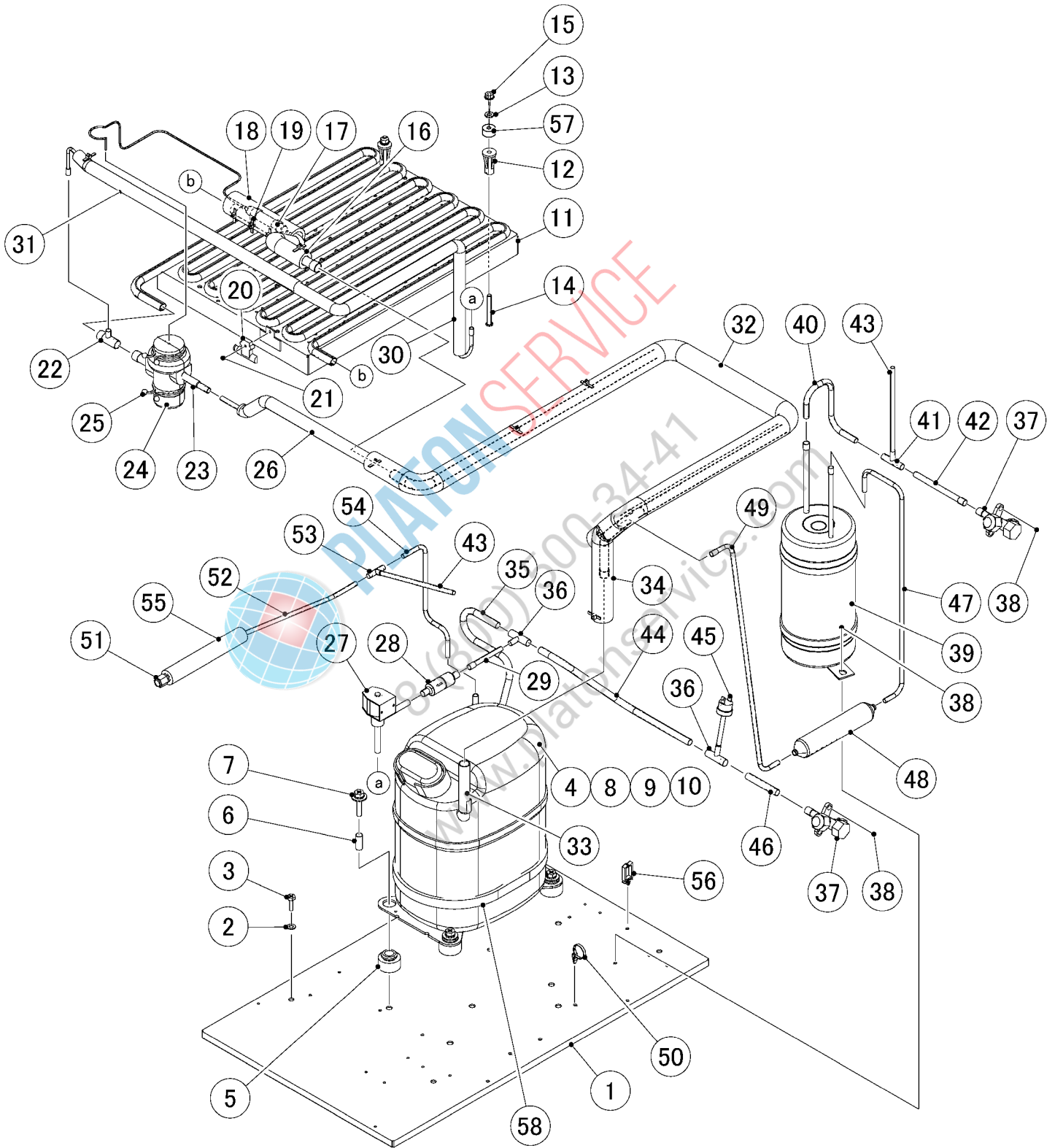

HE

MODEL : **IM-240DSNE(-23)**
IM-240XSNE(-23)

TITLE : **B. REFRIGERATION ASSY**

INDEX NO.	DESCRIPTION	MATERIAL OR MODEL NUMBER	PART NUMBER	REQ'D NUMBER				
				C-1 G-0	G-1			
1	BASE		3Y6699G02	1	1			
2	FLAT WASHER		FWPL06N0	4	4			
3	HEX HEAD BOLT		FBH0620S0	4	4			
4	COMPRESSOR		P01855-01	1	1			
5	RUBBER GROMMET		P01858-01	4	4			
6	SLEEVE		P01859-01	4	4			
7	BOLT		436206-03	4	4			
8	COVER		P01857-01	1	1			
9	CLAMP		P01862-01	1	1			
10	GASKET		P01863-01	1	1			
11	EVAPORATOR	(240DSNE,XSNE)	2H7526G01	1	1			
		(240DSNE-23,XSNE-23)	2H1833G03	1	1			
12	COLLAR		3H3879-01	4	4			
13	WASHER		4H0777-01	4	4			
14	SCREW EVAPORATOR	(240DSNE,XSNE)	4Y4922M02	4	4			
		(240DSNE-23,XSNE-23)	4Y4922M03	4	4			
15	FLANGE NUT		FNHF06S0	4	4			
16	PIPE(B)-LOW SIDE		4Y6625G01	1	1			
17	CLIP		452254-02	2	2			
18	INSULATION		4X8643-01	1	1			
19	TIE		7920-0003	10	10			
20	HOLDER - THERMISTOR		3H9642-01	1	1			
21	S-TITE TRUSS HEAD SCREW		FTS0408M0	1	1			
22	TEE		430608-02	1	1			
23	EXPANSION VALVE		P01874-01	1	1			
24	VALVE COVER		3Y3051P01	1	1			
25	CLAMP		P00752-01	2	2			
26	PIPE(C)-HIGH SIDE		3Y5229G01	1	1			
27	HOT GAS VALVE		P04242-01	1	1			
28	STRAINER		P00812-01	1	1			
29	COPPER TUBE(A)-HOT GAS		4Y8058M01	1	1			
30	PIPE(B)-HOT GAS		3Y7267G01	1	1			
31	PIPE(C)-HOT GAS		3Y7268G01	1	1			
32	HEAT EXCHANGER		2X1152G01	1	1			
33	PIPE(A-2)-LOW SIDE		4Y6612M01	1	1			

IM-240DNE(-C, -21, -23, -32)

IM-240XNE(-21, -23, -32)

IM-240DSNE(-23)

IM-240XSNE(-23)

C. MECHANISM ASSY

(K-1) and later

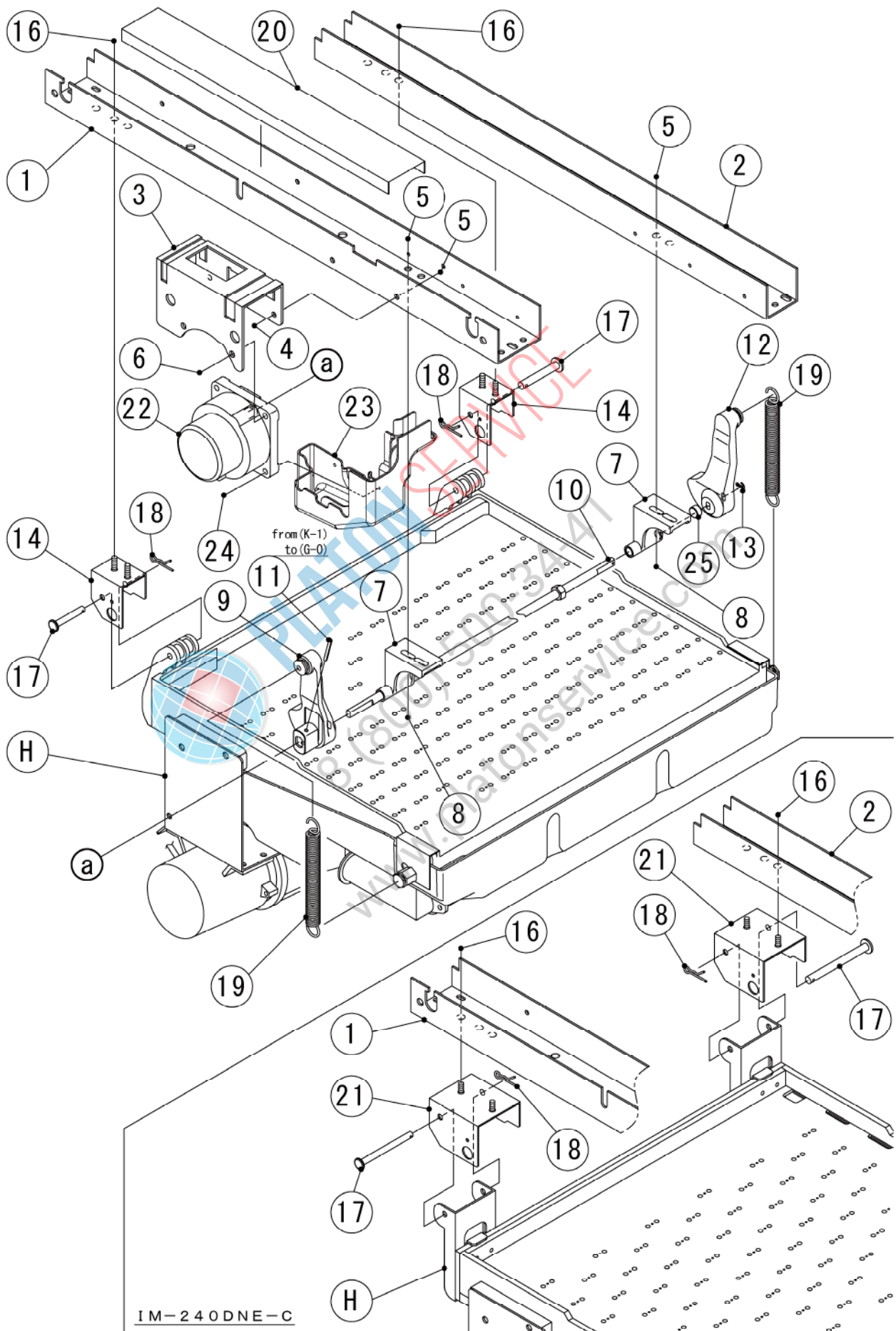

HE,GENERAL(50Hz)(60Hz),HSP,AUSTRALIA,CHINA,KOREA(60Hz)

MODEL : IM-240DNE(-C,-21,-23,-32) IM-240XNE(-21,-23,-32) IM-240DSNE(-23) IM-240XSNE(-23)								
TITLE : C. MECHANISM ASSY								
INDEX NO.	DESCRIPTION	MATERIAL OR MODEL NUMBER	PART NUMBER	REQ'D NUMBER				
				K-1 B-0	B-1 B-2	B-3 C-0	C-1 G-0	G-1
H	WATER PAN ASSY	-	1H4689A01	1	1	1	1	1
		(240DNE-C)	1H4680A01	1	1	1	1	1
1	FRONT FRAME	-	3Y5020M01	1	1	1	1	1
2	REAR FRAME	-	3Y5021M01	1	1	1	1	1
3	BRACKET - AM	-	3Y2924M01	1	1	1	1	1
4	TRUSS HEAD MACHINE SCREW	-	FST0512S0	2	2	2	2	2
5	FLANGE NUT	-	FNHF05S0	6	6	6	6	6
6	HEX HEAD BOLT (SPRING WASHER AND FLAT WASHER)	-	FBK0620S0	2	2	2	2	2
7	BEARING - CAM SHAFT	-	3X8307-02	2	2	2	2	2
8	TRUSS HEAD MACHINE SCREW	-	FST0516S0	4	4	4	4	-
	HEX HEAD BOLT (SPRING WASHER AND FLAT WASHER)	-	FBK0516S1	-	-	-	-	4
9	CAM(A)	-	306543G03	1	1	1	1	-
		-	306543G04	-	-	-	-	1
10	CAM SHAFT	-	425511G02	1	1	1	1	1
11	SPRING PIN 3*28	-	712S-0328	1	1	1	1	-
12	CAM (B)	-	376546P01	1	1	1	1	1
13	COTTER PIN	-	711S-0212	1	1	1	1	1
14	BEARING PLATE	(EXCEPT 240DNE-C)	3H1440G03	2	2	2	2	2
15	BEARING PLATE	(EXCEPT 240DNE-C)	3H1440G04	-	-	-	-	-
16	FLANGE NUT	-	FNHF06S0	4	4	4	4	4
17	SHAFT (B)	-	4H1184-02	2	2	2	2	2
	SHAFT (A)	(240DNE-C)	4H1184-01	2	2	2	2	2
18	SNAP PIN	-	715S-0006	2	2	2	2	2
19	EXTEN SPRING	-	4H3473-01	2	2	2	2	2
20	GUIDE - CONNECTOR	-	4H5619-01	1	1	1	1	1
21	BEARING - WATER PAN	(240DNE-C)	3Y5036G01	2	2	2	2	2
22	ACTUATOR MOTOR	-	4Y8998G01	1	1	1	1	1
23	COVER - ACTUATOR MOTOR	-	1H4881P01	1	1	1	1	1
24	T2 TRUSS HEAD SCREW	-	FT20416M0	2	2	2	2	2
25	COLLAR	(240DNE-21,-32 240XNE-21,-32)	429124-01	1	1	1	1	1

IM-240DNE(-C,-21,-23,-32)

IM-240XNE(-21,-23,-32)

IM-240DSNE(-23)

IM-240XSNE(-23) D. WATER CIRCUIT ASSY (K-1) and later

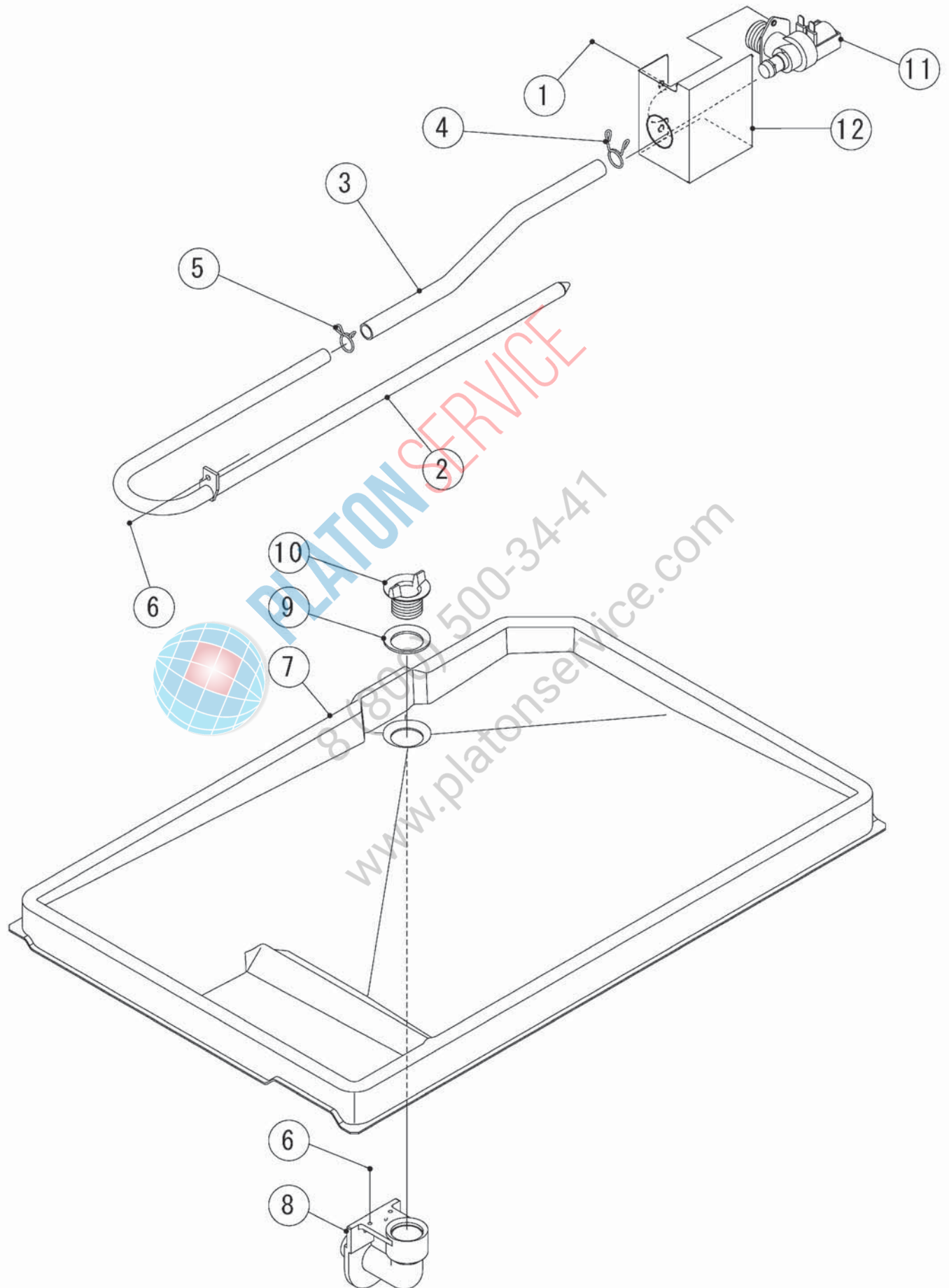

HE,GENERAL(50Hz)(60Hz),HSP,AUSTRALIA,CHINA,KOREA(60Hz)

MODEL : IM-240DNE(-C,-21,-23,-32) IM-240XNE(-21,-23,-32) IM-240DSNE(-23) IM-240XSNE(-23)								
TITLE : D. WATER CIRCUIT ASSY								
INDEX NO.	DESCRIPTION	MATERIAL OR MODEL NUMBER	PART NUMBER	REQ'D NUMBER				
				K-1 B-0	B-1 B-2	B-3 C-0	C-1 G-0	G-1
1	TRUSS HEAD MACHINE SCREW	-	FST0408S0	2	2	2	2	2
2	WATER SUPPLY PIPE	-	3H9533G01	1	1	1	1	1
3	SILICONE HOSE	-	2H9942-01	1	1	1	1	1
4	HOSE CLAMP	SWC-80C(15mm)	435934-03	1	1	1	1	1
5	HOSE CLAMP	SWC-80C(14mm)	435934-02	1	1	1	1	1
6	TRUSS HEAD MACHINE SCREW	-	FST0412S0	3	3	3	3	3
7	DRAIN PAN	-	208186-01	1	1	1	1	1
8	DRAIN PIPE	-	315825-01	1	1	1	1	1
9	PACKING	-	413857-01	1	1	1	1	1
10	DRAIN YOKE	-	418296-01	1	1	1	1	1
11	WATER VALVE	-	P01872-01	1	1	1	1	1
12	COVER-WATER VALVE	-	3Y6090M01	1	1	1	1	1



8 (800) 500-3441
www.platonservice.com

IM-240DNE (-C, -21, -23, -32)
IM-240XNE (-21, -23, -32)

E. CONTROL BOX ASSY

50Hz (K-1) to (B-0)
60Hz (K-1) to (C-0)

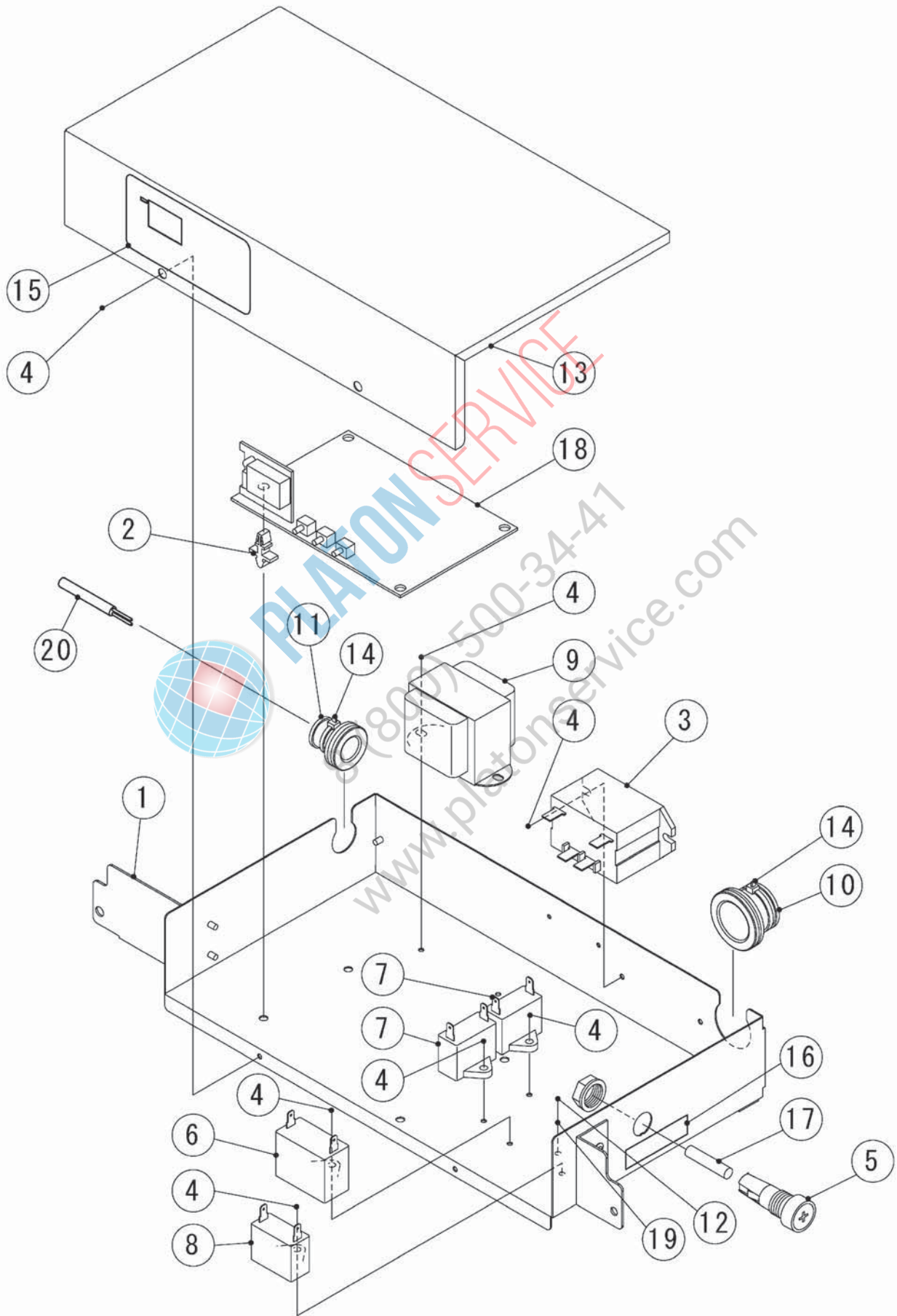

IM-240DNE(-C,-21,-23,-32)

IM-240XNE(-21,-23,-32)

IM-240DSNE(-23)

IM-240XSNE(-23)

E. CONTROL BOX ASSY

(50Hz)(B-1) and later

(60Hz)(C-1) and later

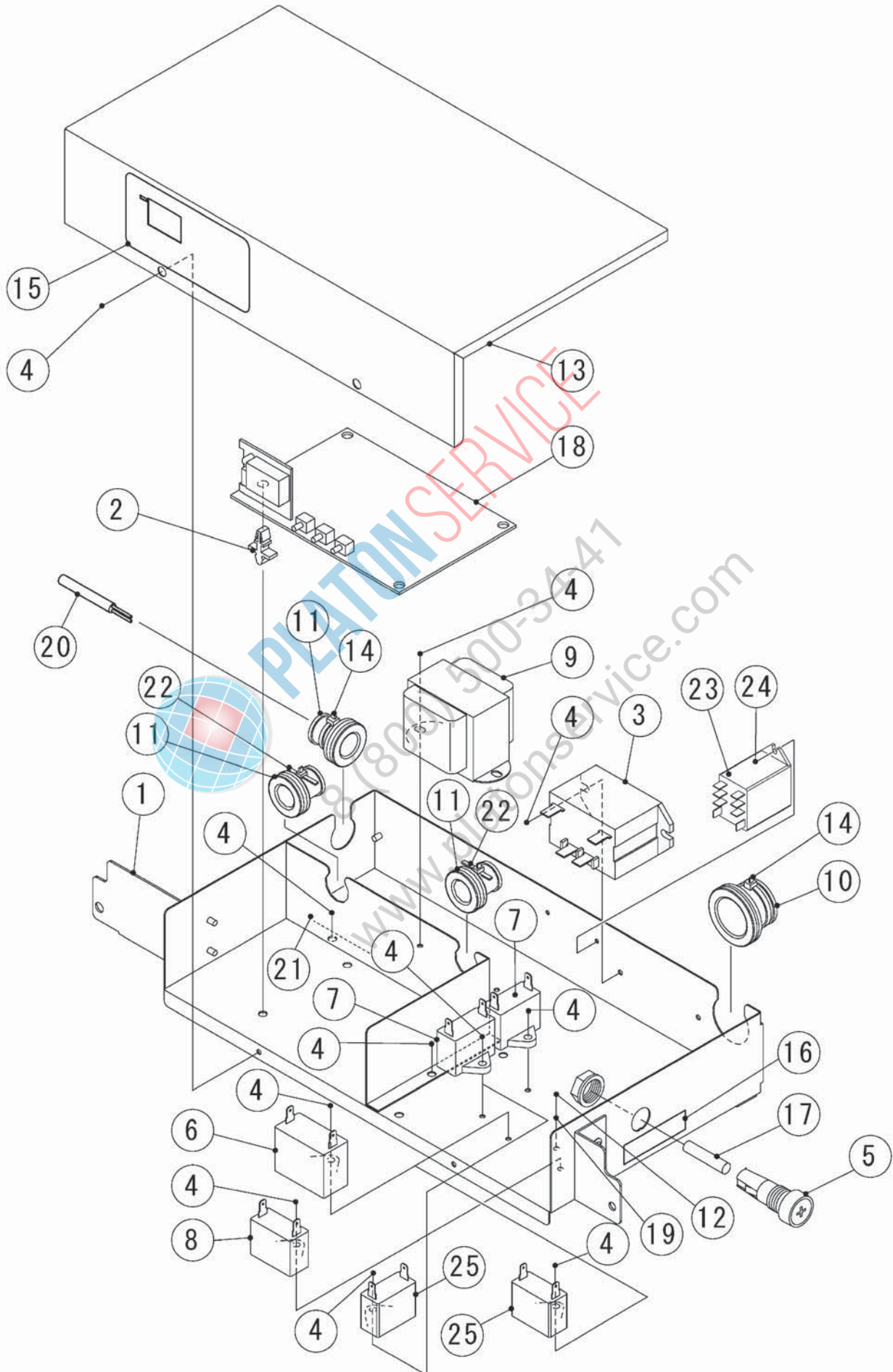

HE,GENERAL(50Hz)(60Hz),HSP,AUSTRALIA,CHINA,KOREA(60Hz)

MODEL : IM-240DNE(-C,-21,-23,-32) IM-240XNE(-21,-23,-32) IM-240DSNE(-23) IM-240XSNE(-23)								
TITLE : E. CONTROL BOX ASSY								
INDEX NO.	DESCRIPTION	MATERIAL OR MODEL NUMBER	PART NUMBER	REQ'D NUMBER				
				K-1 B-0	B-1 B-2	B-3 C-0	C-1 G-0	G-1
1	CONTROL BOX G	(50Hz)	3Y5076G01	1	-	-	-	-
			3Y6694G01	-	1	-	-	-
			3Y7203G01	-	-	1	1	1
		(60Hz)	3Y5076G01	1	1	1	-	-
			3Y7203G01	-	-	-	1	1
2	BOARD SUPPORT	-	P04204-01	4	4	4	4	4
3	POWER RELAY	-	P00034-01	1	1	1	1	1
4	TRUSS HEAD TAPPING SCREW T2	(50Hz)	FT20408F0	10	-	-	-	-
				-	12	12	12	12
		(60Hz)	FT20408F0	10	10	10	-	-
				-	-	-	12	12
5	FUSE HOLDER	(50Hz)	P00014-01	1	1	-	-	-
				P02829-01	-	-	1	1
		(60Hz)	P00014-01	1	1	1	-	-
				P02829-01	-	-	-	1
6	CAPACITOR	EXCEPT (240DSNE,-23) (240XSNE,-23)	P01865-01	1	1	1	1	1
7	CAPACITOR	EXCEPT (240DSNE,-23) (240XSNE,-23)	P01870-01	2	2	2	2	2
8	CAPACITOR	-	P01910-01	1	1	1	1	1
9	TRANSFORMER	-	P02714-01	1	1	1	1	1
10	GROMMET	-	4H2568-01	1	1	1	1	1
11	GROMMET	(50Hz)	4H2568-02	1	3	3	3	3
		(60Hz)		1	1	1	3	3
12	TRUSS HEAD TAPPING SCREW (S-TITE)	-	FTS0408M0	1	1	1	1	1
13	CONTROL BOX COVER	(50Hz)	3Y5077M01	1	-	-	-	-
				3Y6696M01	-	1	1	1
		(60Hz)	3Y5077M01	1	1	1	-	-
				3Y6696M01	-	-	-	1
14	NYLON TIE	CV-100	7920-0002	2	-	-	-	-
15	CONTROL LABEL	-	475006L01	1	1	1	1	1
		(KOREA 60Hz)	475641L01	1	1	1	1	1
16	LABEL - FUSE	-	466798-01	1	1	1	1	1

HE,GENERAL(50Hz)(60Hz),HSP,AUSTRALIA,CHINA,KOREA(60Hz)

MODEL : IM-240DNE(-C,-21,-23,-32) IM-240XNE(-21,-23,-32) IM-240DSNE(-23) IM-240XSNE(-23)								
TITLE : E. CONTROL BOX ASSY								
INDEX NO.	DESCRIPTION	MATERIAL OR MODEL NUMBER	PART NUMBER	REQ'D NUMBER				
				K-1 B-0	B-1 B-2	B-3 C-0	C-1 G-0	G-1
17	FUZE	(50Hz)	P01876-01	1	1	-	-	-
			P04203-01	-	-	1	1	1
		(60Hz)	P01876-01	1	1	1	-	-
			P04203-01	-	-	-	1	1
18	CONTROLLER BOARD	-	P01873-01	1	1	1	1	1
19	SPRING WASHER	-	FWSP04S0	1	1	1	1	1
20	THERMISTOR-CUBE COTROL	-	P00350-01	1	1	1	1	1
21	SEPARATOR - BOX	(50Hz)	3Y6695M01	-	1	1	1	1
		(60Hz)		-	-	-	1	1
22	NYLON TIE	(50Hz)	7920-0001	-	2	2	2	2
		(60Hz)		-	-	-	2	2
23	RELAY	(240DSNE,-23) (240XSNE,-23)	406132-08	-	-	-	1	1
24	TAPPING SCREW	(240DSNE,-23) (240XSNE,-23)	431415-03	-	-	-	2	2
25	CAPACITOR	(240DSNE,-23) (240XSNE,-23)	P01870-01	-	-	-	2	2



8 (800) 500-3447
www.platonservice.com

IM-240DNE(-C,-21,-23,-32)

IM-240XNE(-21,-23,-32)

IM-240DSNE(-23)

IM-240XSNE(-23)

F. CONTROL BOX B-ASSY

(K-1) and later

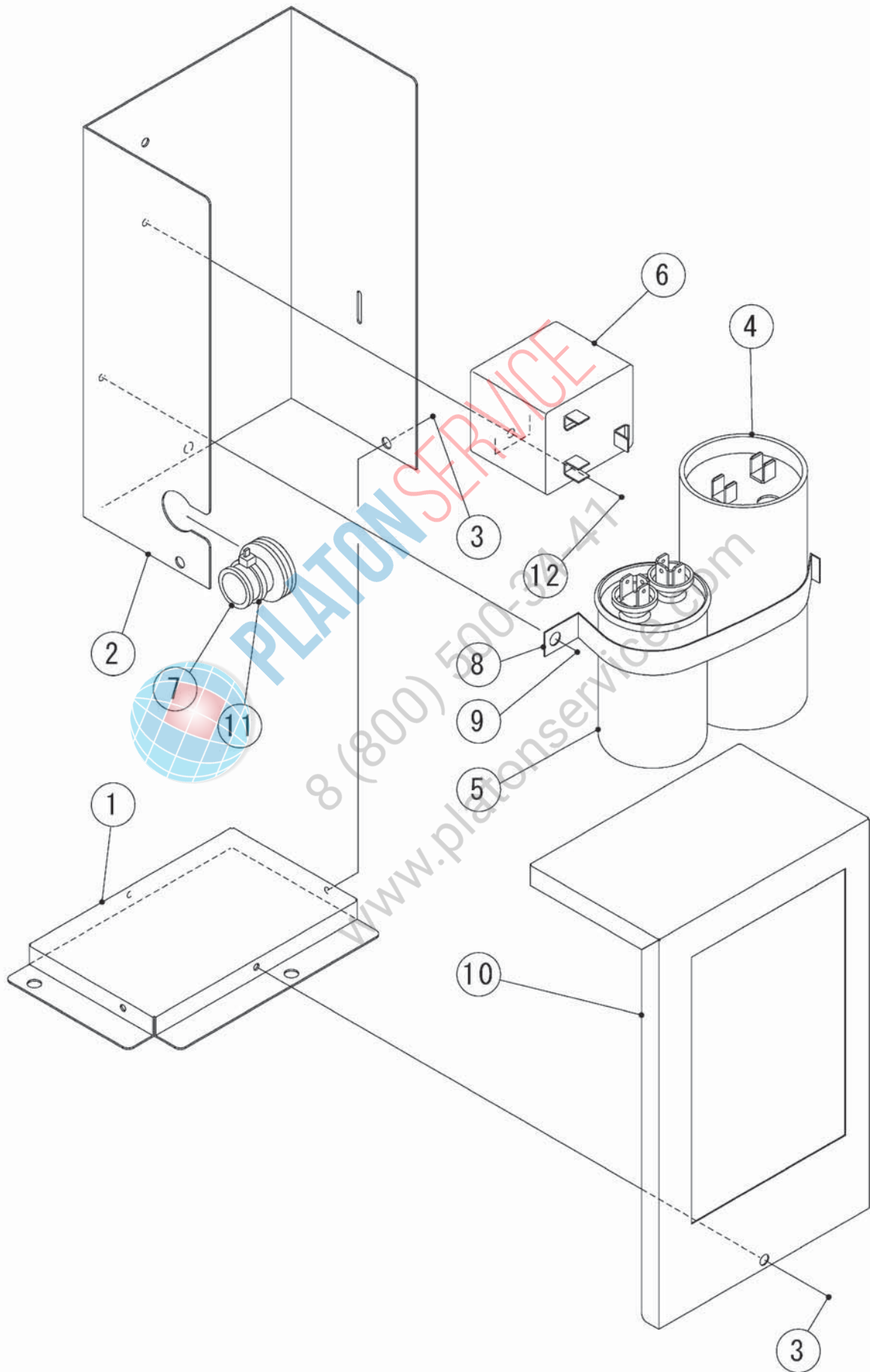

IM-240DNE(-C, -21, -23, -32)
IM-240DSNE(-23)

G. BIN SWITCH ASSY

(K-1) and later

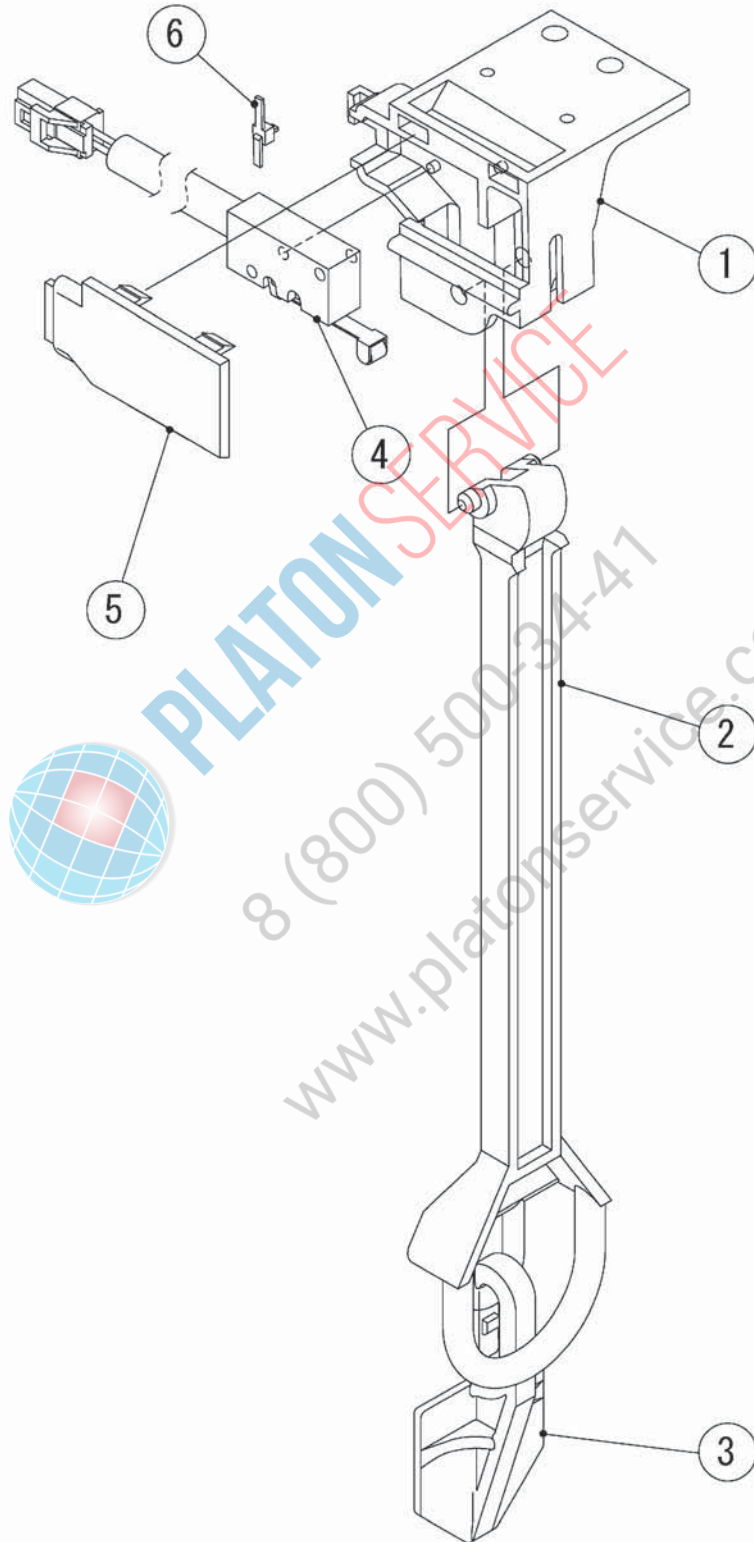

IM-240XNE (-21, -23, -32)
IM-240XSNE(-23)

G. BIN SWITCH ASSY

(K-1) and later

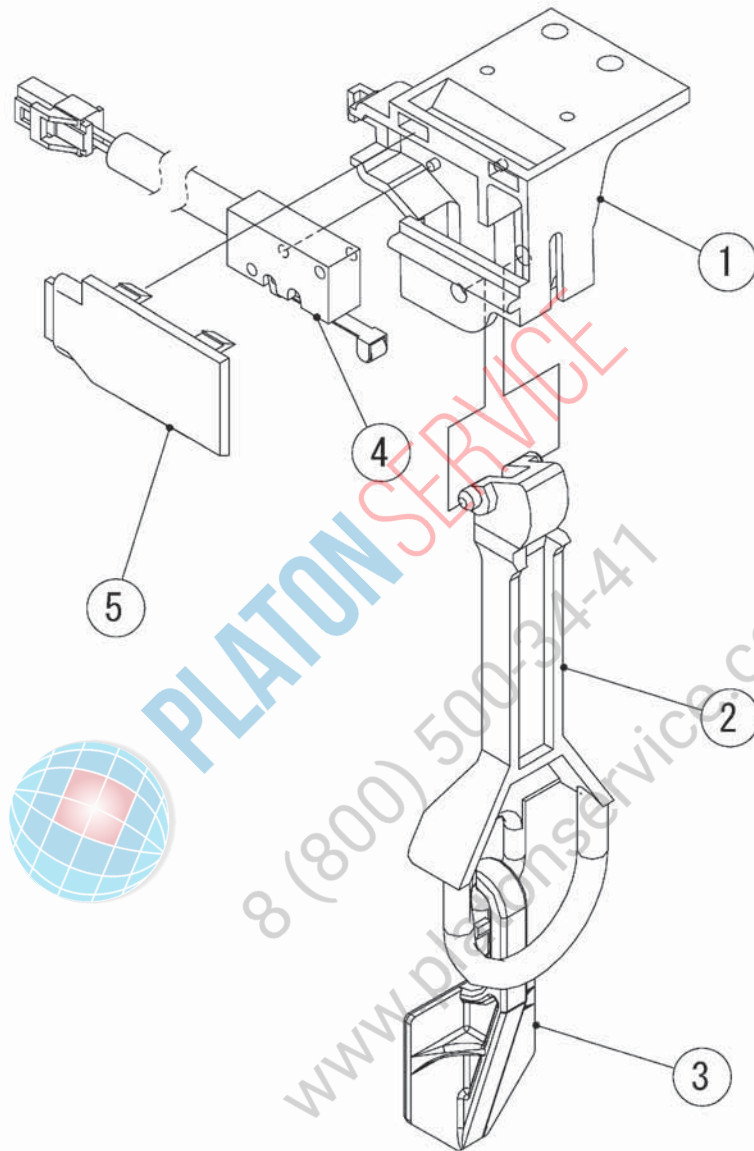

HE,GENERAL(50Hz)(60Hz),HSP,AUSTRALIA,CHINA,KOREA(60Hz)

MODEL : IM-240DNE(-C,-21,-23,-32) IM-240XNE(-21,-23,-32) IM-240DSNE(-23) IM-240XSNE(-23)								
TITLE : G. BIN SWITCH ASSY								
INDEX NO.	DESCRIPTION	MATERIAL OR MODEL NUMBER	PART NUMBER	REQ'D NUMBER				
				K-1 B-0	B-1 B-2	B-3 C-0	C-1 G-0	G-1
1	SWITCH BOX	-	2H2043-01	1	1	1	1	1
2	SWITCH ACTUATOR	(240DNE,-C,-21,-23,-32) (240DSNE,-23)	3H1369-02	1	1	1	1	1
		(240XNE,-21,-23,-32) (240XSNE,-23)	3H1369-01	1	1	1	1	1
3	DETECTOR	-	311044-01	1	1	1	1	1
4	MICRO SWITCH G	-	4Y6741G01	1	1	1	1	1
5	SWITCH BOX COVER	-	4H8785-01	1	1	1	1	1
6	NYLON TIE	(240DNE,-C,-21,-23,-32) (240DSNE,-23)	7920-0002	1	1	1	1	1



PLATON SERVICE
 8 (800) 500-34-41
www.platonservice.com

IM-240DNE(-C, -21, -23, -32)
IM-240XNE(-21, -23, -32)
IM-240DSNE(-23)
IM-240XSNE(-23)

H.WATER PAN ASSY

(K-1) and later

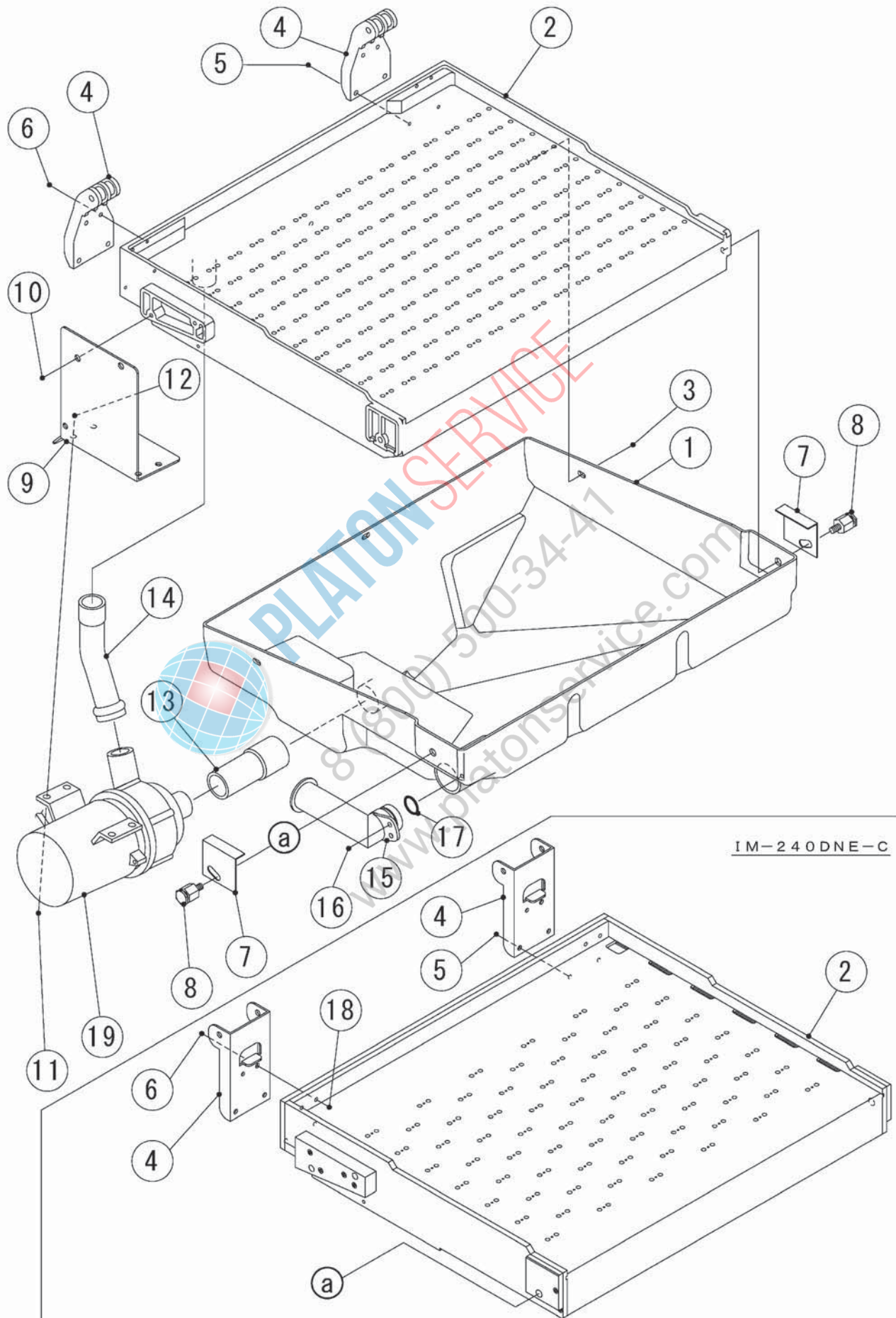

HE,GENERAL(50Hz)(60Hz),HSP,AUSTRALIA,CHINA,KOREA(60Hz)

MODEL : IM-240DNE(-C,-21,-23,-32) IM-240XNE(-21,-23,-32) IM-240DSNE(-23) IM-240XSNE(-23)								
TITLE : H. WATER PAN ASSY								
INDEX NO.	DESCRIPTION	MATERIAL OR MODEL NUMBER	PART NUMBER	REQ'D NUMBER				
				K-1 B-0	B-1 B-2	B-3 C-0	C-1 G-0	G-1
1	WATER PAN	-	1H0888-02	1	1	1	1	1
2	WATER PLATE	(240DNE, -23, 240XNE, -23) (240DSNE, -23) (240XSNE, -23)	208020G01	1	1	1	1	1
		(240DNE-21, XNE-21)	208484G01	1	1	1	1	1
		(240DNE-32, XNE-32)	1H0351G01	1	1	1	1	1
		(240DNE-C)	1H4700G01	1	1	1	1	1
3	TRUSS HEAD TAPPING SCREW T2	(240DNE, -23 240XNE, -23 240DNE-C) (240DSNE, 23) (240XSNE, -23)	FT20406M0	3	3	3	3	3
	TRUSS HEAD MACHINE SCREW	(240DNE-21, -32 240XNE-21, -32)	FST0408S0	3	3	3	3	3
4	WATER PAN HANGER	-	3H2059-01	2	2	2	2	2
	BRACKET - WATER PAN	(240DNE-C)	4Y6595M01	2	2	2	2	2
5	TRUSS HEAD TAPPING SCREW T2	(240DNE, -23, 240XNE, -23) (240DSNE, 23) (240XSNE, -23)	FT20416M0	4	4	4	4	4
	TRUSS HEAD MACHINE SCREW	(240DNE-21,-32 240XNE-21,-32 240DNE-C)	FST0420S0	4	4	4	4	4
6	TRUSS HEAD TAPPING SCREW T2	(240DNE, -23, 240XNE, -23) (240DSNE, -23) (240XSNE, -23)	FT20425M0	4	4	4	4	4
	TRUSS HEAD MACHINE SCREW	(240DNE-21,-32 240XNE-21,-32 240DNE-C)	FST0425S0	4	4	4	4	4
7	BRACKET	-	402957-01	2	2	2	2	2
8	SCREW SPRING HOOK	-	4H2582G01	2	2	2	2	2
9	BRACKET - PUMP	-	4Y6617M01	1	1	1	1	1
10	TRUSS HEAD TAPPING SCREW T2	(240DNE, -23, 240XNE, -23) (240DSNE, -23) (240XSNE, -23)	FT20516M0	2	2	2	2	2
	TRUSS HEAD MACHINE SCREW	(240DNE-21,-32 240XNE-21,-32 240DNE-C)	FST0516S0	2	2	2	2	2
11	HEX HEAD BOLT (SPRING WASHER AND FLAT WASHER)	-	FBK0412S0	4	4	4	4	4
12	FLANGE NUT	-	FNHF04S0	4	4	4	4	4
13	SUCTION TUBE	-	4Y6641R01	1	1	1	1	1
14	DISCHARGE TUBE	-	4Y6642R01	1	1	1	1	1
15	PIPE - DRAIN	-	315530-01	1	1	1	1	1
16	TRUSS HEAD MACHINE SCREW	-	FST0410S0	1	1	1	1	1

HE,GENERAL(50Hz)(60Hz),HSP,AUSTRALIA,CHINA,KOREA(60Hz)

MODEL : IM-240DNE(-C,-21,-23,-32) IM-240XNE(-21,-23,-32) IM-240DSNE(-23) IM-240XSNE(-23)								
						TITLE : H. WATER PAN ASSY		
INDEX NO.	DESCRIPTION	MATERIAL OR MODEL NUMBER	PART NUMBER	REQ'D NUMBER				
				K-1 B-0	B-1 B-2	B-3 C-0	C-1 G-0	G-1
17	O-RING	-	7611-G025	1	1	1	1	1
18	NUT	(240DNE-21,-32 240XNE-21,-32 240DNE-C)	FNH104S0	4	4	4	4	4
19	PUMP MOTOR	PMX-352BHZ1S	P02715-01	1	1	1	1	1



PLATON SERVICE

8 (800) 500-34-47

www.platonservice.com

IM-240DNE(-C,-21,-23,-32)
IM-240XNE(-21,-23,-32)
IM-240DSNE(-23)
IM-240XSNE(-23)

J. FRONT COVER

(K-1) and later

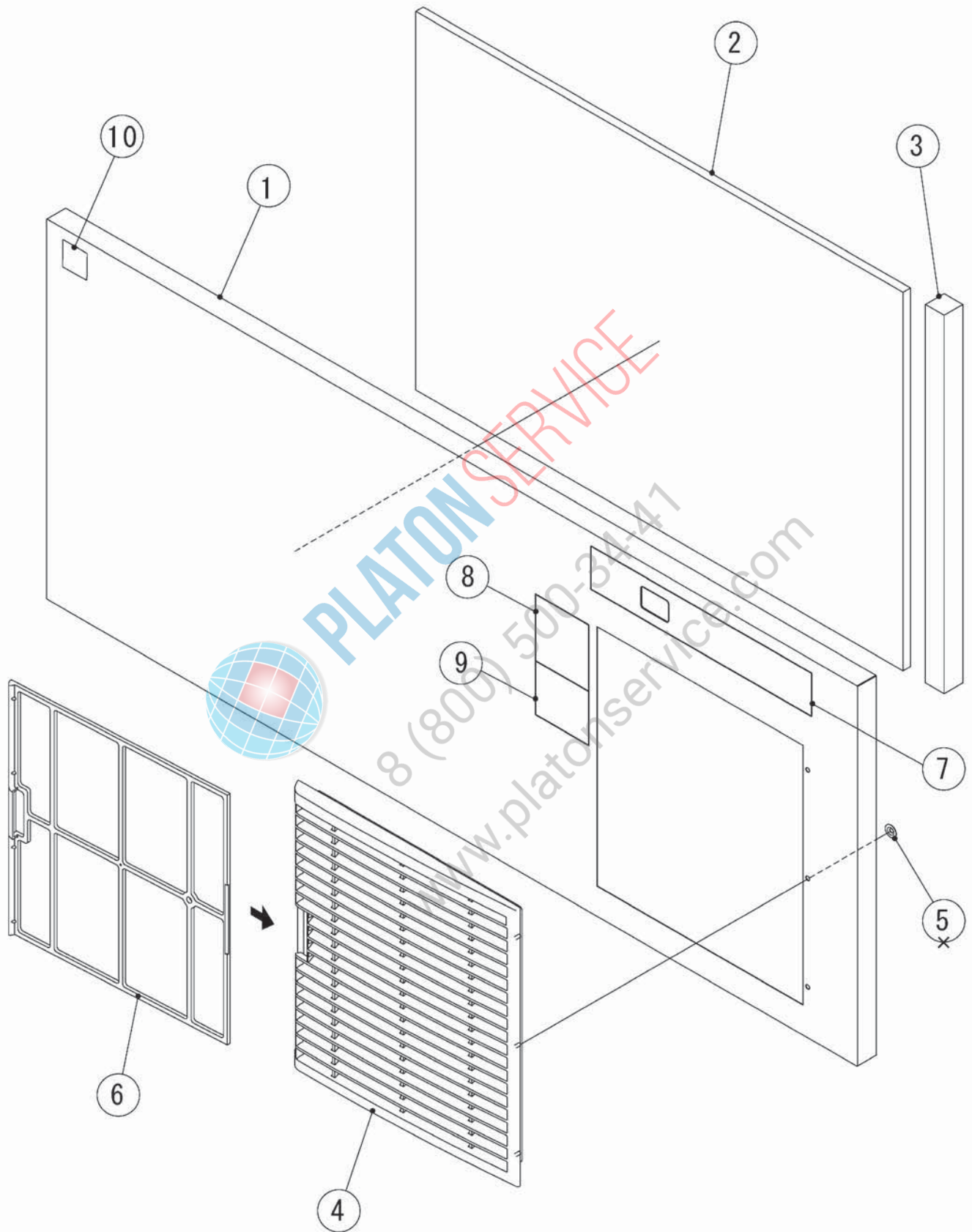

IM-240DNE(-C, -21, -23, -32)
IM-240XNE(-21, -23, -32)
IM-240DSNE(-23)
IM-240XSNE(-23)

K. ACCESSORIES

(K-1) and later

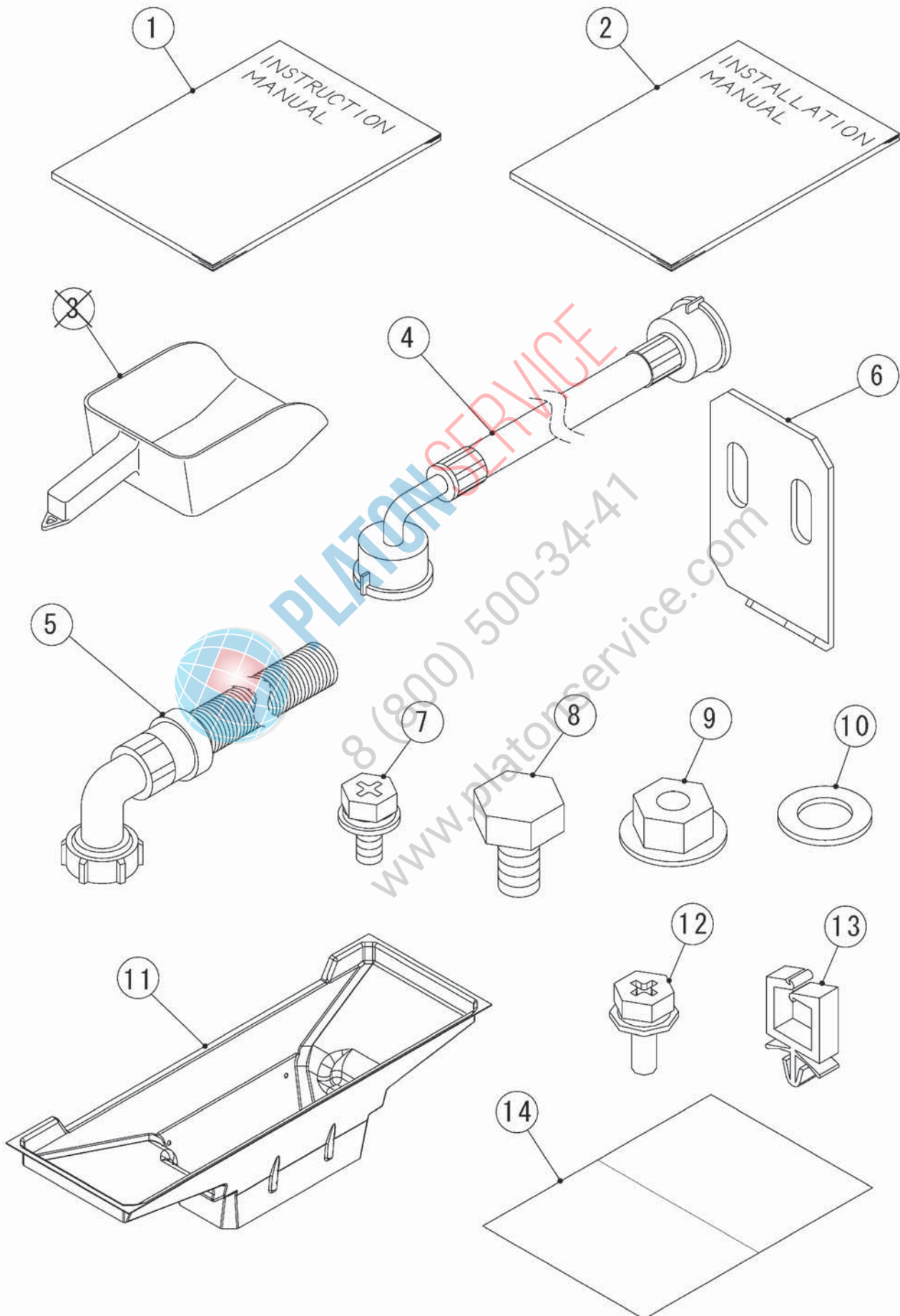

IM-240DNE(-C, -21, -23, -32)
IM-240XNE(-21, -23, -32)
IM-240DSNE(-23)
IM-240XSNE(-23)

L.OPTIONAL PARTS

(K-1) and later

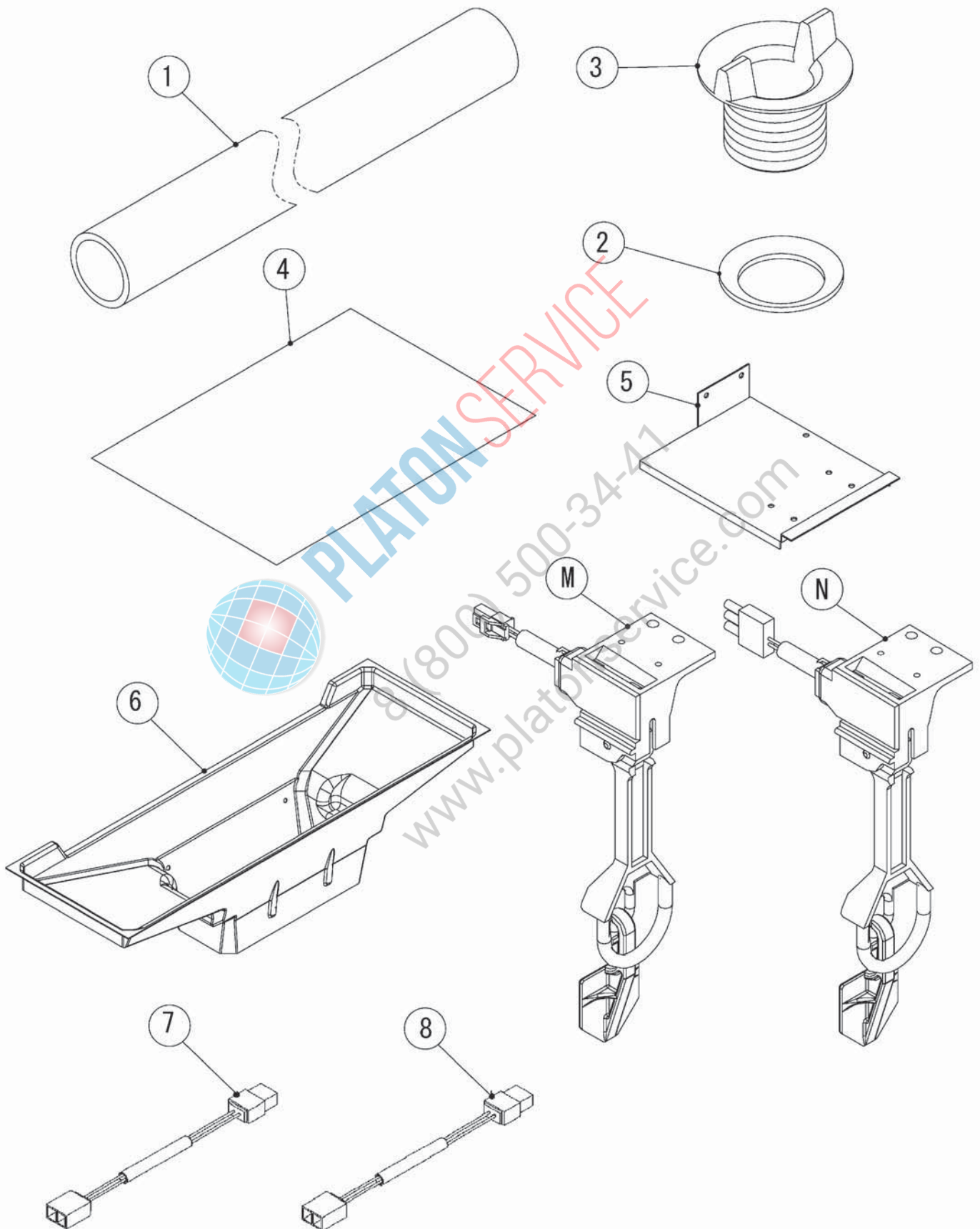

HE,GENERAL(50Hz)(60Hz),HSP,AUSTRALIA,CHINA,KOREA(60Hz)

MODEL : IM-240DNE(-C,-21,-23,-32) IM-240XNE(-21,-23,-32) IM-240DSNE(-23) IM-240XSNE(-23)								
TITLE : L. OPTIONAL PARTS								
INDEX NO.	DESCRIPTION	MATERIAL OR MODEL NUMBER	PART NUMBER	REQ'D NUMBER				
				K-1 B-0	B-1 B-2	B-3 C-0	C-1 G-0	G-1
M	BIN SWITCH AY	-	3Y5244A01	1	1	1	1	1
N	BIN SWITCH AY	-	3Y5245A01	1	1	1	1	1
1	DRAIN PIPE	-	4Y5987P01	1	1	1	1	1
2	PACKING	-	413857-01	1	1	1	1	1
3	DRAIN YOKE	-	418296-01	1	1	1	1	1
4	INSTALLATION SHEET-DRAIN KIT	-	372945L01	1	1	1	1	1
5	BRACKET-BIN CONTROL SWITCH	-	4Y5943M01	1	1	1	1	1
6	ICE SHOOT G	-	2H9615G01	1	1	1	1	1
7	CABLE (A) -KIT	-	4Y5177G01	1	1	1	1	1
8	CABLE (B) -KIT	-	4Y5179G01	1	1	1	1	1



PLATON SERVICE

8 (800) 500-34-41

www.platonservice.com

IM-240DNE(-C,-21,-23,-32)
IM-240XNE(-21,-23,-32)
IM-240DSNE(-23)
IM-240XSNE(-23)

M. BIN SWITCH ASSY

(K-1) and later

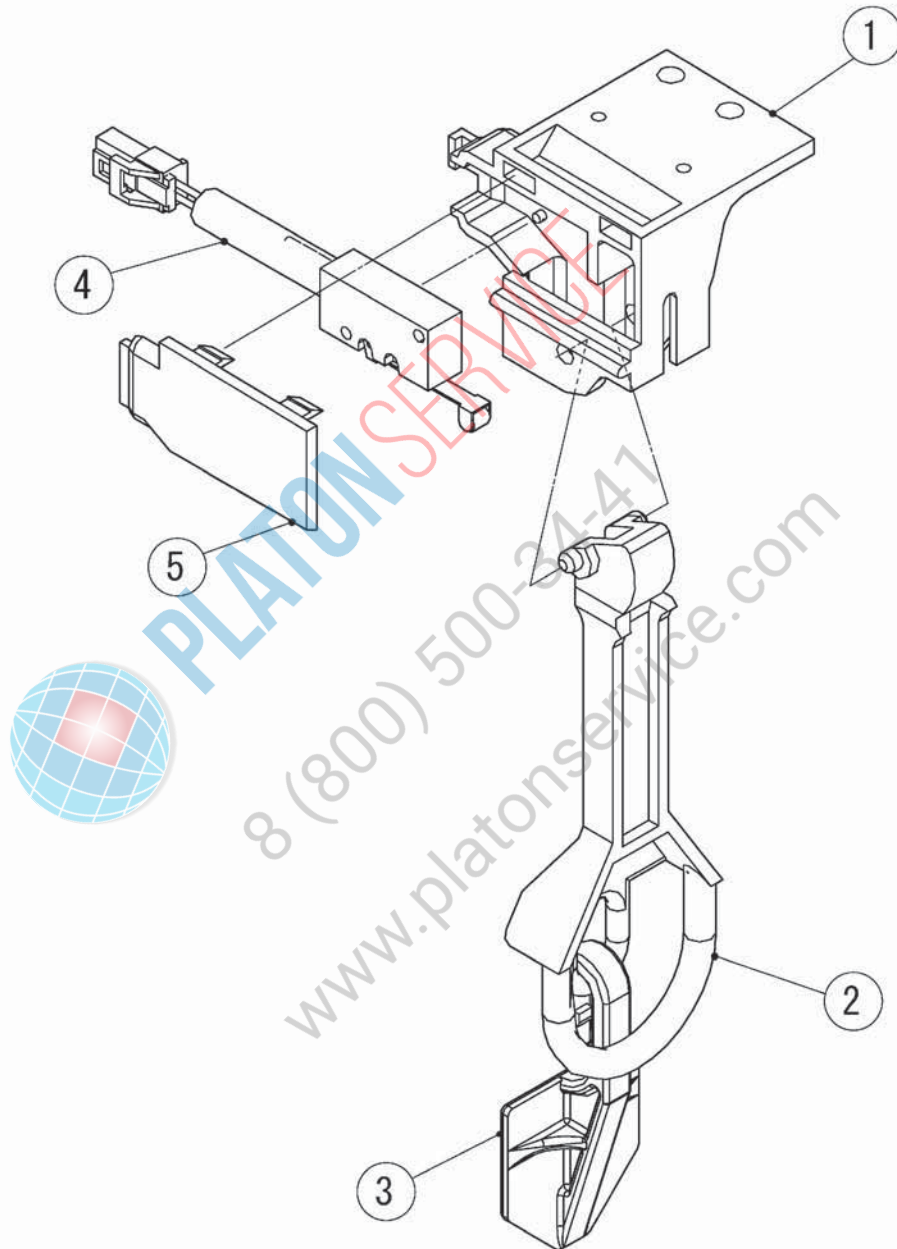

HE,GENERAL(50Hz)(60Hz),HSP,AUSTRALIA,CHINA,KOREA(60Hz)

MODEL : IM-240DNE(-C,-21,-23,-32) IM-240XNE(-21,-23,-32) IM-240DSNE(-23) IM-240XSNE(-23)								
						TITLE : M. BIN SWITCH ASSY		
INDEX NO.	DESCRIPTION	MATERIAL OR MODEL NUMBER	PART NUMBER	REQ'D NUMBER				
				K-1 B-0	B-1 B-2	B-3 C-0	C-1 G-0	G-1
1	SWITCH BOX	-	2H2043-01	1	1	1	1	1
2	SWITCH ACTUATOR	-	3H1369-01	1	1	1	1	1
3	DETECTOR	-	311044-01	1	1	1	1	1
4	MICRO SWITCH G	-	4Y6741G01	1	1	1	1	1
5	SWITCH BOX COVER	-	4H8785-01	1	1	1	1	1



PLATON SERVICE

8 (800) 500-34-41

www.platonservice.com

IM-240DNE(-C,-21,-23,-32)

IM-240XNE(-21,-23,-32)

IM-240DSNE(-23)

IM-240XSNE(-23)

N. BIN SWITCH ASSY

(K-1) and later

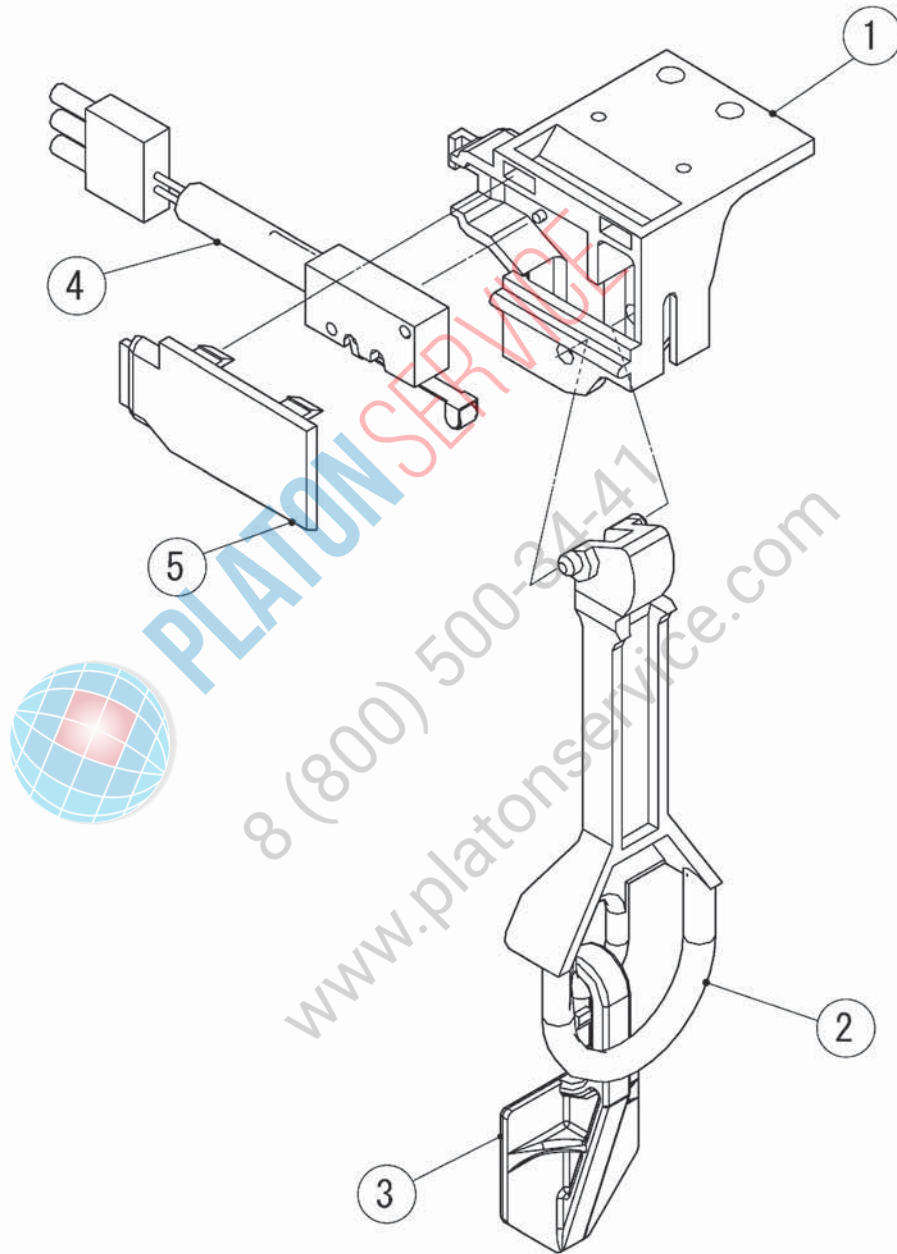

HE,GENERAL(50Hz)(60Hz),HSP,AUSTRALIA,CHINA,KOREA(60Hz)

MODEL : IM-240DNE(-C,-21,-23,-32) IM-240XNE(-21,-23,-32) IM-240DSNE(-23) IM-240XSNE(-23)								
						TITLE : N. BIN SWITCH ASSY		
INDEX NO.	DESCRIPTION	MATERIAL OR MODEL NUMBER	PART NUMBER	REQ'D NUMBER				
				K-1 B-0	B-1 B-2	B-3 C-0	C-1 G-0	G-1
1	SWITCH BOX	-	2H2043-01	1	1	1	1	1
2	SWITCH ACTUATOR	-	3H1369-01	1	1	1	1	1
3	DETECTOR	-	311044-01	1	1	1	1	1
4	MICRO SWITCH G	-	4Y6788G01	1	1	1	1	1
5	SWITCH BOX COVER	-	4H8785-01	1	1	1	1	1



PLATON SERVICE

8 (800) 500-34-41

www.platonservice.com